RS90LV011 3.3V LVDS Single High Speed Differential Driver

1 FEATURES

- **Conforms to TIA/EIA-644-A Standard**
- **>400Mbps (200MHz) Switching Rates**
- **700ps Maximum Differential Skew**
- **1.5ns Maximum Propagation Delay**
- **Single 3.3V Power Supply**
- **±350mV Differential Signaling**
- **Pinout Simplifies PCB layout**
- **Low Power Dissipation (18mW@3.3V Typical)**
- **SOT-23 5-Lead Package**
- **Industrial Temperature Operating Range (-40°C ~85°C)**

3 ADVANTAGES

- >400Mbps Switching Rates
- 4mA output short current.
- 18mW low power dissipation.
- SOT-23 5-Lead Package.

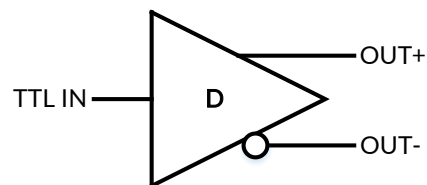

Figure 1. Functional Diagram

2 APPLICATIONS

- **Multifunction Printers**
- **LVC MOS-LVDS Translation**
- **Building and Factory Automation**
- **Grid Infrastructure**

Table of Contents

1 FEATURES	1
2 APPLICATIONS	1
3 ADVANTAGES	1
4 Revision History	3
5 DESCRIPTIONS	4
6 PIN CONIGURATIONS	5
7 SPECIFICATIONS	6
7.1 Absolute Maximum Ratings	6
7.2 Recommended Operating Conditions	6
7.3 ESD Ratings	6
7.4 Electrical Characteristics	7
7.5 Switching Characteristics	7
8 Parameter Measurement Information	8
9 PACKAGE OUTLINE DIMENSIONS	9

4 Revision History

Note: Page numbers for previous revisions may differ from page numbers in the current version.

VERSION	Change Date	Change Item
A.0	2023/08/14	Initial version
A.1	2024/01/08	Add Min and Max measurement results

5 DESCRIPTIONS

The RS90LV011 is positioned as a single-channel LVDS driver for high-speed, low-power application scenarios. The RS90LV011 is a current-mode driver, so it can be used at high frequencies and still guarantee low power consumption. The RS90LV011 can support LVDS data rates up to 400Mbps (200MHz). The target markets for this product are communications and industrial.

6 PIN CONIGURATIONS

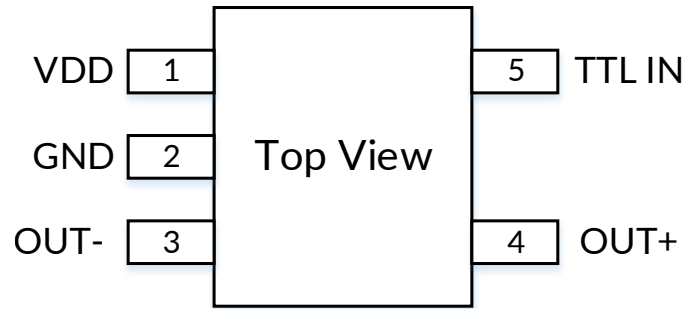

Figure 2. Pin Definition

Pin Description

PIN	NAME	FUNCTION
SOT-23		
5	TTL IN	LVTTTL/LVCMOS driver input pins
4	OUT+	Non-inverting driver output pin
3	OUT-	Inverting driver output pin
2	GND	Ground pin
1	VDD	Power supply pin, +3.3±0.3V

7 SPECIFICATIONS

7.1 Absolute Maximum Ratings

PARAMETER	VALUE	UNIT
Supply Voltage (VDD)	-0.3 to 4	V
LVC MOS input voltage (TTL IN)	-0.3 to 3.6	V
LVDS output voltage (OUT \pm)	-0.3 to 3.9	V
Thermal Resistance (θ_{JA})	138.5	$^{\circ}\text{C}/\text{W}$
Storage Temperature	-65 to 150	$^{\circ}\text{C}$
Maximum Junction Temperature	+150	$^{\circ}\text{C}$

Note:

- "Absolute Maximum Ratings" are those values beyond which the safety of the device cannot be specified. They are not meant to imply that the devices should be operated at these limits.

7.2 Recommended Operating Conditions

	MIN	TYP	MAX	UNIT
Supply Voltage(VDD)	3	3.3	3.6	V
Temperature (T_A)	-40	25	85	$^{\circ}\text{C}$

7.3 ESD Ratings

The following ESD information is provided for handling of ESD-sensitive devices in an ESD protected area only.

		VALUE	UNIT
$V_{(ESD)}$	HBM(1.5k Ω ,100pF)	≥ 8000	V
	CDM(0 Ω ,0pF)	≥ 2000	V
	LATCH UP	≥ 400	mA



Electric devices and circuit boards may discharge undetected. Although this product has a patented or proprietary protection circuit, the device may be damaged when exposed to high energy ESD. Therefore, appropriate ESD prevention measures should be taken to avoid device performance degradation or loss of function.

7.4 Electrical Characteristics

Over Supply Voltage and Operating Temperature ranges, unless otherwise specified.

SYMBOL	PARAMETER	CONDITIONS	MIN	TYP	MAX	UNIT
V _{OD}	Output Differential Voltage	R _L =100Ω (Figure 3)	250	350	450	mV
V _{OS}	VOD Magnitude Change	R _L =100Ω (Figure 3)	1.125	1.25	1.375	V
I _{OS}	Output Short Circuit Current	V _{OUT+} =0 and V _{OUT-} =0		-4.5	-10	mA
I _{OSD}	Differential Output Short Circuit Current	V _{OD} =0		-4.4	-8	mA
C _{OUT}	Output Capacitance			3		pF
V _{IH}	Input High Voltage		2		V _{DD}	V
V _{IL}	Input Low Voltage		GND		0.8	V
I _{IH}	Input High Current	V _{IN} =3.3V or 2.4V		0	±10	uA
I _{IL}	Input Low Current	V _{IN} =0 or 0.5V		0	±10	uA
C _{IN}	Input Capacitance			3		pF
I _{DD}	Power Supply Current	No Load		4.5	7	mA
		R _L =100Ω	V _{IN} =V _{DD} or 0	5.3	7	mA

Note:

1. Current into device pins is defined as positive. Current out of device pins is defined as negative.
2. All typicals are given for: V_{DD}=3.3V and T_A=25°C.

7.5 Switching Characteristics

Over Supply Voltage and Operating Temperature ranges, unless otherwise specified.

SYMBOL	PARAMETER	CONDITIONS	MIN	TYP	MAX	UNIT
t _{PHLD}	Differential Propagation Delay High to Low	R _L =100Ω (Figure 4 and Figure 5)	0.3	0.8	1.5	ns
t _{PLHD}	Differential Propagation Delay Low to High		0.3	0.7	1.5	ns
t _{SKD1}	Differential Pulse Skew t _{PHLD} - t _{PLHD}		0	0.1	0.7	ns
t _{TLH}	Transition Low to High Time		0.2	0.5	1	ns
t _{THL}	Transition High to Low Time		0.2	0.5	1	ns
f _{MAX}	Maximum Operating Frequency		200	250		MHz

Note:

1. Generator waveform for all tests unless otherwise specified: f=1MHz, Z_o=50Ω, t_r≤1ns, t_f≤1ns (10%-90%).
2. f_{MAX} generator input conditions: t_r=t_f<1 ns (0%-100%), 50%, 0 to 3V. Output criteria: duty cycle = 45%-55%, V_{OD}>250mV.
3. Figure 3 shows the test circuits used for |V_{OD}| and V_{OS} tests, and Figure 4 shows the test circuits used for switching characteristics.

8 Parameter Measurement Information

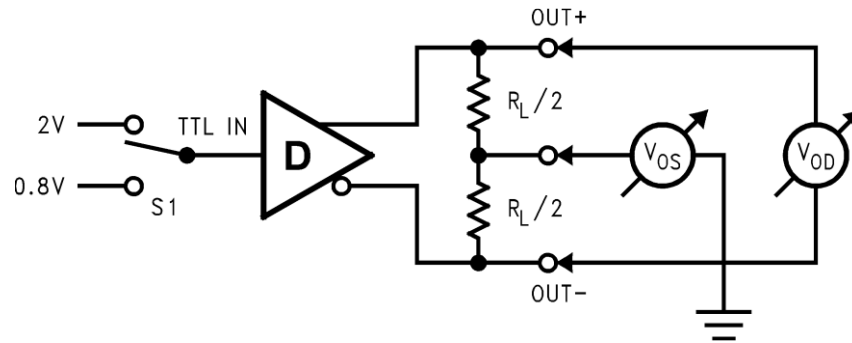

Figure 3. Differential Driver DC Test Circuit

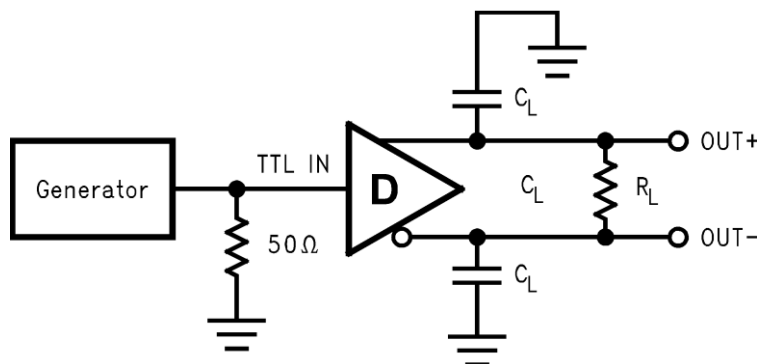

Figure 4. Differential Driver Propagation Delay and Transition Time Test Circuit

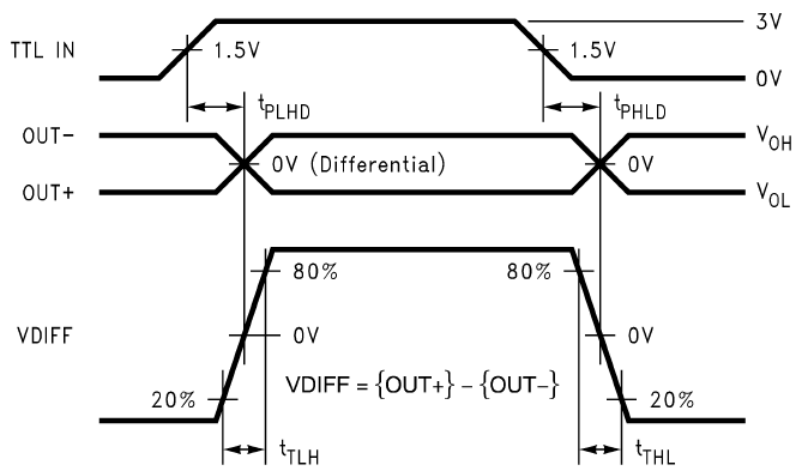

Figure 5. Differential Driver Propagation Delay and Transition Time Waveforms

9 PACKAGE OUTLINE DIMENSIONS

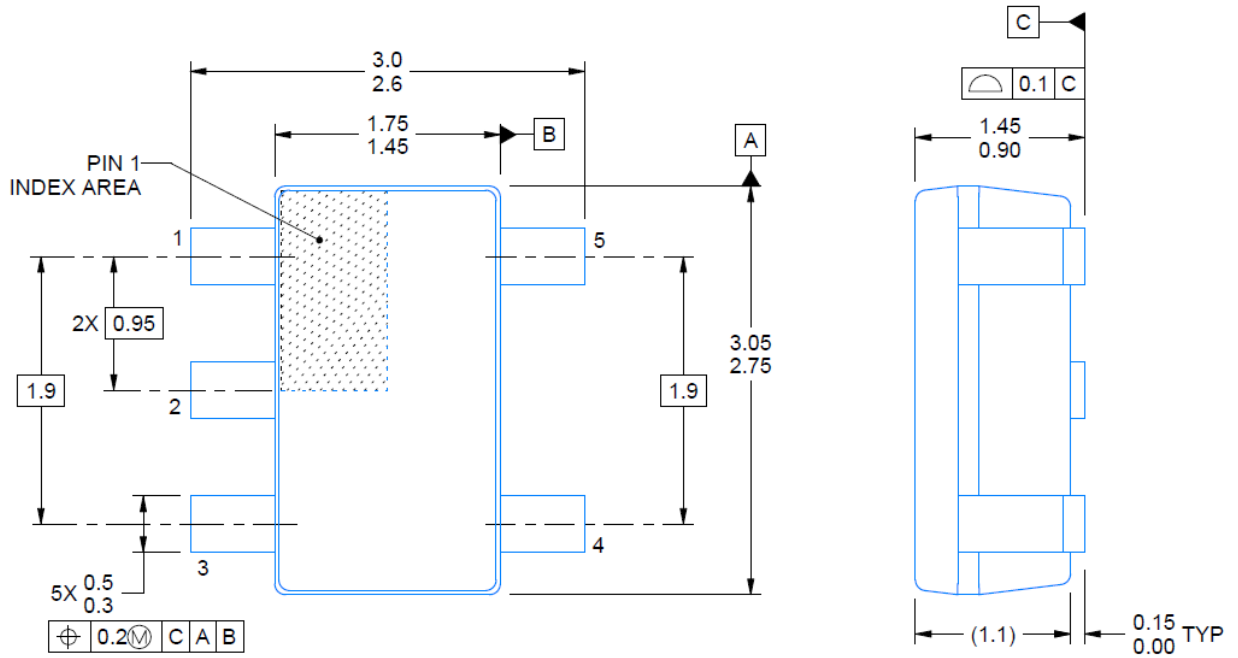

Figure 6. SOT-23 and Dimensions