

250MHz, Rail-to-Rail Input/Output CMOS Operational Amplifier

1 FEATURES

- **Unity-Gain Bandwidth: 250MHz**
- **Gain Bandwidth: 120MHz**
- **High Slew Rate: 180V/μs**
- **Offset Voltage: 1mV typical**
- **Low Noise: 6nV/√Hz**
- **Input Voltage Range: V_{DD}-0.1V to V_{DD}+0.1V with V_s = 5V**
- **High Output Current: >100mA**
- **Supply Range: +2.7V to +5.5V**
- **Specified Up To +125°C**

2 APPLICATIONS

- **Audio ADC Input Buffers**
- **Photodiode Preamp**
- **High-Density Systems**
- **Portable Systems**
- **Driving A/D Converters**
- **Video Processing**

3 DESCRIPTIONS

The RS876X families of voltage-feedback (VFB) products offer low voltage operation, rail to rail input and output, as well as excellent speed/power consumption ratio, providing an excellent bandwidth (250MHz) and slew rate of 180V/μs. The op-amps are unity gain stable and feature an ultra-low input bias current.

These amplifiers set an industry-leading power-to-performance ratio for rail-to-rail amplifiers. The RS876X families of operational amplifiers are specified at the full temperature range of -40°C to +125°C under single or dual power supplies of 2.7V to 5.5V.

Device Information ⁽¹⁾

PART NUMBER	PACKAGE	BODY SIZE(NOM)
RS8761	SOT23-5	2.90mm×1.60mm
RS8762	SOP8	4.90mm×3.90mm
	MSOP8	3.00mm×3.00mm
	TSSOP8	3.00mm×4.40mm
RS8764	SOP14	8.65mm×3.90mm
	TSSOP14	5.00mm×4.40mm

(1) For all available packages, see the orderable addendum at the end of the data sheet

Table of Contents

1 FEATURES	1
2 APPLICATIONS	1
3 DESCRIPTIONS	1
4 REVISION HISTORY	3
5 PACKAGE/ORDERING INFORMATION ⁽¹⁾	4
6 PIN CONFIGURATION AND FUNCTIONS (TOP VIEW)	5
7 SPECIFICATIONS	7
7.1 Absolute Maximum Ratings	7
7.2 ESD Ratings	7
7.3 Recommended Operating Conditions	8
7.4 Electrical Characteristics	9
7.5 Typical Characteristics	11
8 DETAILED DESCRIPTION	13
8.1 Overview	13
8.2 Power On Requirement	13
8.3 Phase Reversal Protection	13
8.4 Gain Bandwidth Product	13
8.5 Capacitive Load Driving Capability	14
8.6 Video Performance	14
8.7 Output Drive Capability	14
8.8 Input ESD Diode Protection	14
8.9 Power Supply Bypassing and Printed Circuit Board Layout	15
9 APPLICATION AND IMPLEMENTATION	16
9.1 Application Note	16
9.2 Single Supply Video Line Driver	16
10 PACKAGE OUTLINE DIMENSIONS	17
11 TAPE AND REEL INFORMATION	23

4 REVISION HISTORY

Note: Page numbers for previous revisions may differ from page numbers in the current version.

Version	Change Date	Change Item
A.0	2023/04/03	Preliminary version completed
A.1	2024/05/17	Initial version completed

5 PACKAGE/ORDERING INFORMATION ⁽¹⁾

Orderable Device	Package Type	Pin	Channel	Op Temp(°C)	Device Marking ⁽²⁾	MSL ⁽³⁾	Package Qty
RS8761PXF	SOT23-5	5	1	-40°C ~125°C	8761P	MSL3	Tape and Reel, 3000
RS8762PXK-G	SOP8	8	2	-40°C ~125°C	RS8762P	MSL1	Tape and Reel, 4000
RS8762PXM	MSOP8	8	2	-40°C ~125°C	RS8762P	MSL3	Tape and Reel, 4000
RS8762PXQ	TSSOP8	8	2	-40°C ~125°C	RS8762P	MSL3	Tape and Reel, 4000
RS8764PXP	SOP14	14	4	-40°C ~125°C	RS8764P	MSL3	Tape and Reel, 4000
RS8764PXQ	TSSOP14	14	4	-40°C ~125°C	RS8764P	MSL3	Tape and Reel, 4000

NOTE:

- (1) This information is the most current data available for the designated devices. This data is subject to change without notice and revision of this document. For browser-based versions of this data sheet, refer to the right-hand navigation.
- (2) There may be additional marking, which relates to the lot trace code information (data code and vendor code), the logo or the environmental category on the device.
- (3) MSL, The Moisture Sensitivity Level rating according to the JEDEC industry standard classifications.

6 PIN CONFIGURATION AND FUNCTIONS (TOP VIEW)

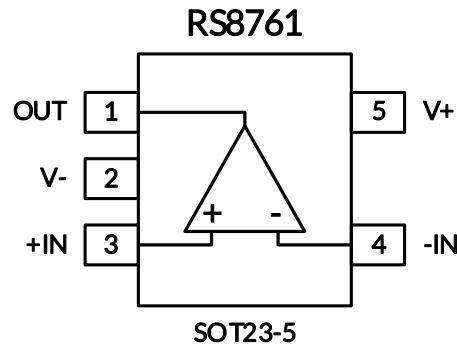

Pin Description

NAME	PIN		I/O ⁽¹⁾	DESCRIPTION
	RS8761			
	SOT23-5			
-IN	4		I	Negative (inverting) input
+IN	3		I	Positive (noninverting) input
OUT	1		O	Output
V-	2		-	Negative (lowest) power supply
V+	5		-	Positive (highest) power supply

(1) I = Input, O = Output.

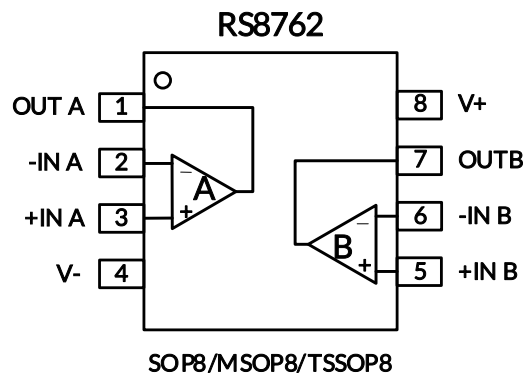

Pin Description

NAME	PIN		I/O ⁽¹⁾	DESCRIPTION
	SOP8/MSOP8/TSSOP8			
-IN A	2		I	Inverting input, channel A
+IN A	3		I	Noninverting input, channel A
-IN B	6		I	Inverting input, channel B
+IN B	5		I	Noninverting input, channel B
OUT A	1		O	Output, channel A
OUT B	7		O	Output, channel B
V-	4		-	Negative (lowest) power supply
V+	8		-	Positive (highest) power supply

(1) I = Input, O = Output.

Pin Configuration and Functions (Top View)

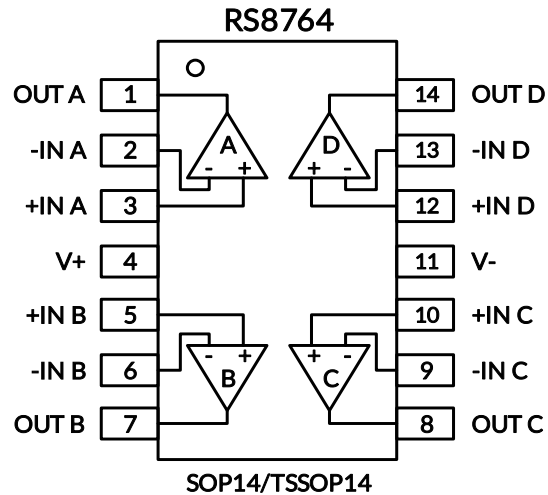

Pin Description

NAME	PIN	I/O ⁽¹⁾	DESCRIPTION
	SOP14/TSSOP14		
-INA	2	I	Inverting input, channel A
+INA	3	I	Noninverting input, channel A
-INB	6	I	Inverting input, channel B
+INB	5	I	Noninverting input, channel B
-INC	9	I	Inverting input, channel C
+INC	10	I	Noninverting input, channel C
-IND	13	I	Inverting input, channel D
+IND	12	I	Noninverting input, channel D
OUTA	1	O	Output, channel A
OUTB	7	O	Output, channel B
OUTC	8	O	Output, channel C
OUTD	14	O	Output, channel D
V-	11	-	Negative (lowest) power supply
V+	4	-	Positive (highest) power supply

(1) I = Input, O = Output.

7 SPECIFICATIONS

7.1 Absolute Maximum Ratings

Over operating free-air temperature range (unless otherwise noted) ⁽¹⁾

		MIN	MAX	UNIT
Voltage	Supply, $V_S=(V+) - (V-)$		7	V
	Signal input pin ⁽²⁾	(V-)-0.3	(V+) +0.3	
	Signal output pin ⁽³⁾	(V-)-0.2	(V+) +0.2	
Current	Signal input pin ⁽²⁾	-10	10	mA
	Signal output pin ⁽³⁾	-50	50	mA
	Output short-circuit ⁽⁴⁾	Continuous		
θ_{JA}	Package thermal impedance ⁽⁵⁾	SOT23-5	230	°C/W
		SOP8	110	
		MSOP8	170	
		SOP14	105	
		TSSOP14	90	
		TSSOP8	240	
Temperature	Operating range, T_A	-40	125	°C
	Junction, T_J ⁽⁶⁾	-40	150	
	Storage, T_{stg}	-65	150	
	Lead temperature (Soldering, 10sec)	260		

(1) Stresses above these ratings may cause permanent damage. Exposure to absolute maximum conditions for extended periods may degrade device reliability. These are stress ratings only, and functional operation of the device at these or any other conditions beyond those specified is not implied.

(2) Input terminals are diode-clamped to the power-supply rails. Input signals that can swing more than 0.3V beyond the supply rails should be current-limited to 10mA or less.

(3) Output terminals are diode-clamped to the power-supply rails. Output signals that can swing more than 0.2V beyond the supply rails should be current-limited to ± 50 mA or less.

(4) A heat sink may be required to keep the junction temperature below the absolute maximum. This depends on the power supply voltage and how many amplifiers are shorted. Thermal resistance varies with the amount of PC board metal connected to the package. The specified values are for short traces connected to the leads.

(5) The package thermal impedance is calculated in accordance with JESD-51.

(6) The maximum power dissipation is a function of $T_{J(MAX)}$, $R_{\theta JA}$, and T_A . The maximum allowable power dissipation at any ambient temperature is $P_D = (T_{J(MAX)} - T_A) / R_{\theta JA}$. All numbers apply for packages soldered directly onto a PCB.

7.2 ESD Ratings

The following ESD information is provided for handling of ESD-sensitive devices in an ESD protected area only.

		VALUE	UNIT
$V_{(ESD)}$	Electrostatic discharge	Human-body model (HBM), per ANSI/ESDA/JEDEC JS-001 ⁽¹⁾	± 5000
		Charged-device model (CDM), per ANSI/ESDA/JEDEC JS-002 ⁽²⁾	± 1500

(1) JEDEC document JEP155 states that 500 V HBM allows safe manufacturing with a standard ESD control process.

(2) JEDEC document JEP157 states that 250 V CDM allows safe manufacturing with a standard ESD control process.



ESD SENSITIVITY CAUTION

ESD damage can range from subtle performance degradation to complete device failure. Precision integrated circuits may be more susceptible to damage because very small parametric changes could cause the device not to meet its published specifications.

7.3 Recommended Operating Conditions

Over operating free-air temperature range (unless otherwise noted)

		MIN	MAX	UNIT
Supply voltage, $V_S = (V+) - (V-)$	Single-supply	2.7	5.5	V
	Dual-supply	±1.35	±2.75	

7.4 Electrical Characteristics

At $T_A = +25^\circ\text{C}$, $V_S = \pm 2.5\text{V}$, $R_F = 0\Omega$, Full⁽⁹⁾ = -40°C to $+125^\circ\text{C}$, unless otherwise noted. ⁽¹⁾

PARAMETER		CONDITIONS	T_A	RS876X			UNIT
				MIN ⁽²⁾	TYP ⁽³⁾	MAX ⁽²⁾	
POWER SUPPLY							
V_S	Operating Voltage Range		Full	2.7		5.5	V
I_Q	Quiescent Current per Amplifier	$V_S = 2.7\text{V}$	25°C		6.3	8.5	mA
			Full			11	
		$V_S = 5\text{V}$	25°C		8.3	10	
			Full			13	
PSRR	Power-Supply Rejection Ratio	$V_S = 2.7\text{V}$ to 5.5V	25°C	65	80		dB
			Full	55			
INPUT							
V_{OS}	Input Offset Voltage	$V_S = 5\text{V}$, $V_{CM} = V_S/2$	25°C	-2	± 1	2	mV
			Full	-3		3	
$V_{OS} T_C$	Input Offset Voltage Drift		Full		± 10		$\mu\text{V}/^\circ\text{C}$
I_B	Input Bias Current ^{(4) (5)}	$V_S = 5\text{V}$	25°C		± 3		pA
			Full		± 300		
I_{OS}	Input Offset Current ⁽⁴⁾	$V_S = 5\text{V}$	25°C		3		pA
C_{IN}	Input Capacitance	Differential Mode	25°C		3.5		pF
		Common Mode	25°C		2.5		
A_{OL}	Open-loop Voltage Gain	$R_{LOAD} = 2\text{k}\Omega$, $V_{OUT} = -2.4\text{V}$ to 2.4V	25°C	95	105		dB
		$R_{LOAD} = 2\text{k}\Omega$, $V_{OUT} = -2.35\text{V}$ to 2.35V	Full	80			
V_{CM}	Common-Mode Voltage Range		Full	(V-)-0.1		(V+)+0.1	V
CMRR	Common-Mode Rejection Ratio	$V_S = 5.0\text{V}$, $V_{CM} = 0$ to 3V	25°C	60	80		dB
			Full	55			
		$V_S = 5.0\text{V}$, $V_{CM} = 0$ to 5V	25°C	60	75		
			Full	55			
OUTPUT							
V_{OH}	Output Swing from Positive Rail	$R_{LOAD} = 100\text{k}\Omega$ to $V_S/2$	25°C		7	20	mV
V_{OL}	Output Swing from Negative Rail	$R_{LOAD} = 100\text{k}\Omega$ to $V_S/2$	25°C		4	20	mV
I_{SC}	Short-Circuit Current ^{(6) (7)}	Source	25°C		200		mA
		Sink			250		
R_{OUT}	Closed-Loop Output Impedance ⁽⁴⁾	$G = 1$, $f = 1\text{kHz}$, $I_{OUT} = 0$	25°C		0.01		Ω
R_O	Open-Loop Output Impedance ⁽⁴⁾	$f = 1\text{kHz}$, $I_{OUT} = 0$			21		Ω
AC Specifications							
f_{-3dB}	Small-Signal Bandwidth ⁽⁴⁾	$G = +1$, $V_O = 100\text{mV}_{PP}$			250		MHz
		$G = +2$, $V_O = 100\text{mV}_{PP}$			90		MHz
GBW	Gain-Bandwidth Product	$G = +10$	25°C		120		MHz
SR	Slew Rate ⁽⁸⁾	$V_S = +5\text{V}$, $G = 1, 4\text{V}$ Step	25°C		200		$\text{V}/\mu\text{s}$
		$V_S = +5\text{V}$, $G = 1, 2\text{V}$ Step			180		
		$V_S = +3\text{V}$, $G = 1, 2\text{V}$ Step			140		

t _F	Rise-and-Fall Time	G = +1, V _O = 200mV _{PP} , 10% to 90%	25°C		7		ns
		G = +1, V _O = 2V _{PP} , 10% to 90%	25°C		2.5		ns
t _S	Settling Time, 0.1% ⁽⁴⁾	G=1, 2V Step	25°C		25		ns
t _{OR}	Overload Recovery Time	V _{IN} * Gain = V _S	25°C		40		ns
PM	Phase Margin ⁽⁴⁾	G=1	25°C		60		deg
NOISE							
E _n	Input Voltage Noise	V _S =5V, f=0.1Hz to 10Hz	25°C		51		μVpp
e _n	Input Voltage Noise Density ⁽⁴⁾	f = 1MHz	25°C		6		nV/√Hz

NOTE:

- (1) Electrical table values apply only for factory testing conditions at the temperature indicated. Factory testing conditions result in very limited self-heating of the device.
- (2) Limits are 100% production tested at 25°C. Limits over the operating temperature range are ensured through correlations using statistical quality control (SQC) method.
- (3) Typical values represent the most likely parametric norm as determined at the time of characterization. Actual typical values may vary over time and will also depend on the application and configuration.
- (4) This parameter is ensured by design and/or characterization and is not tested in production.
- (5) Positive current corresponds to current flowing into the device.
- (6) The maximum power dissipation is a function of T_{J(MAX)}, R_{θJA}, and T_A. The maximum allowable power dissipation at any ambient temperature is P_D = (T_{J(MAX)} - T_A) / R_{θJA}. All numbers apply for packages soldered directly onto a PCB.
- (7) Short circuit test is a momentary test.
- (8) Number specified is the slower of positive and negative slew rates.
- (9) Specified by characterization only.

7.5 Typical Characteristics

NOTE: The graphs and tables provided following this note are a statistical summary based on a limited number of samples and are provided for informational purposes only.

$V_s = 5V$, $G = +1$, $R_F = 0\Omega$, $R_L = 1K\Omega$, and connected to $V_s/2$, unless otherwise specified

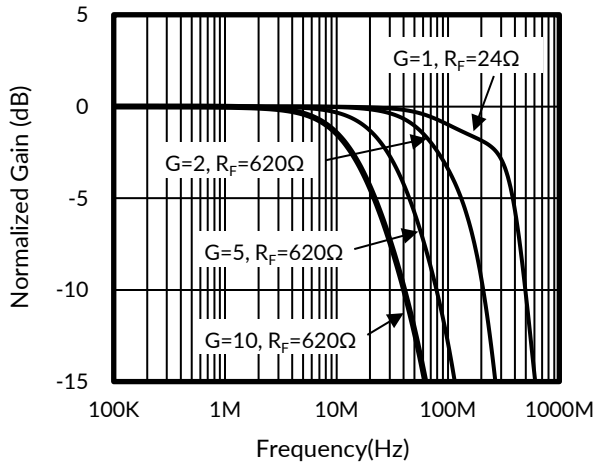

Figure 1. Noninverting Small Signal Frequency Response

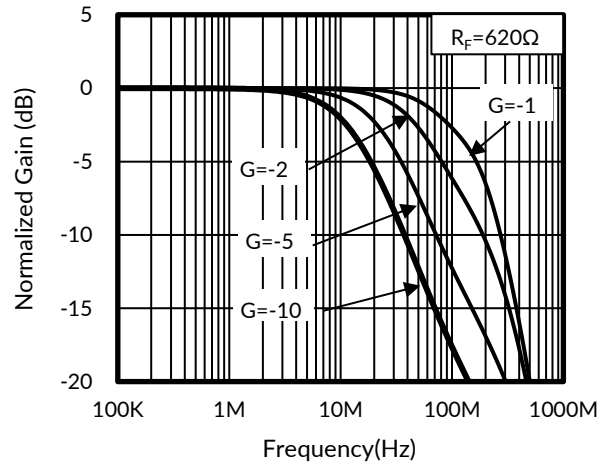

Figure 2. Inverting Small Signal Frequency Response

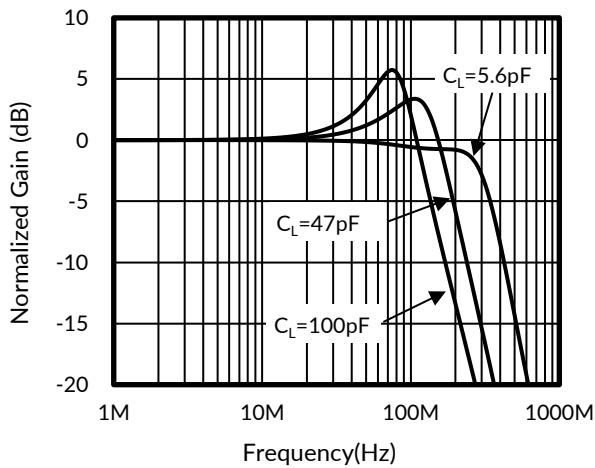

Figure 3. Frequency Response for Various C_L

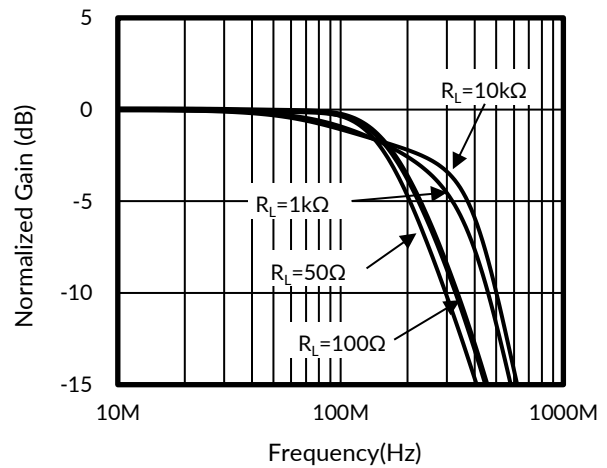

Figure 4. Frequency Response for Various R_L

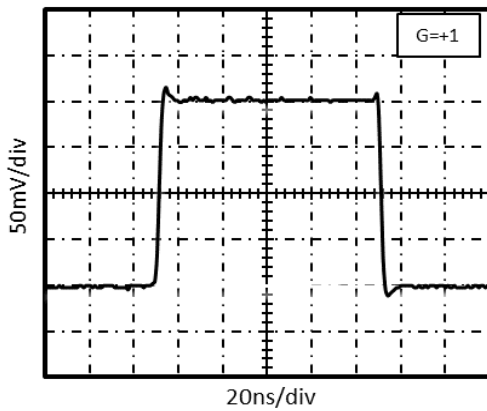

Figure 5. Small Signal Step Response

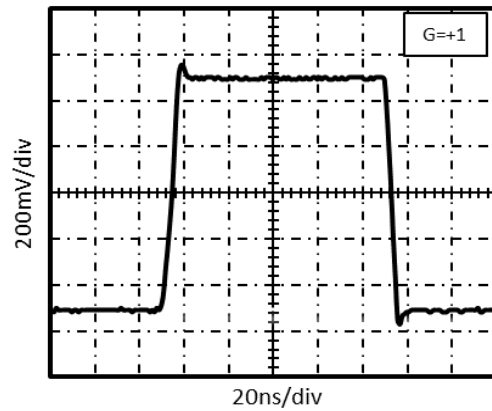

Figure 6. Large Signal Step Response

Typical Characteristics

NOTE: The graphs and tables provided following this note are a statistical summary based on a limited number of samples and are provided for informational purposes only.

$V_S = 5V$, $G = +1$, $R_F = 0\Omega$, $R_L = 1K\Omega$, and connected to $V_S/2$, unless otherwise specified

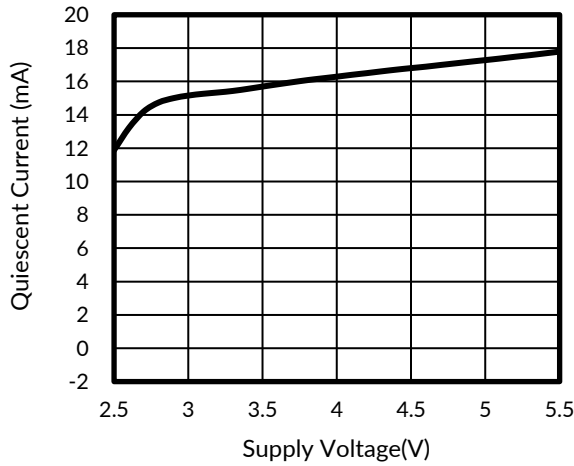

Figure 7. Quiescent Current vs Supply Voltage

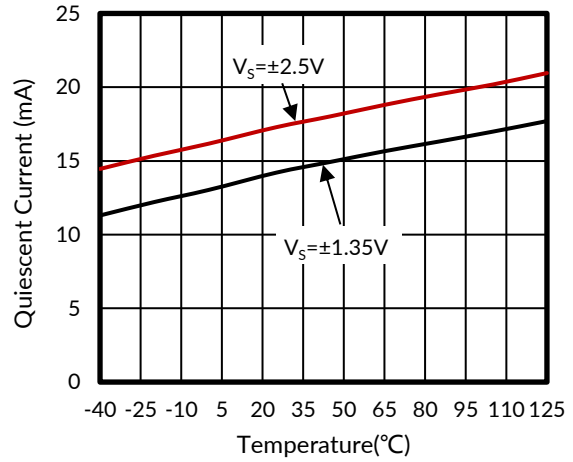

Figure 8. Quiescent Current vs Temperature

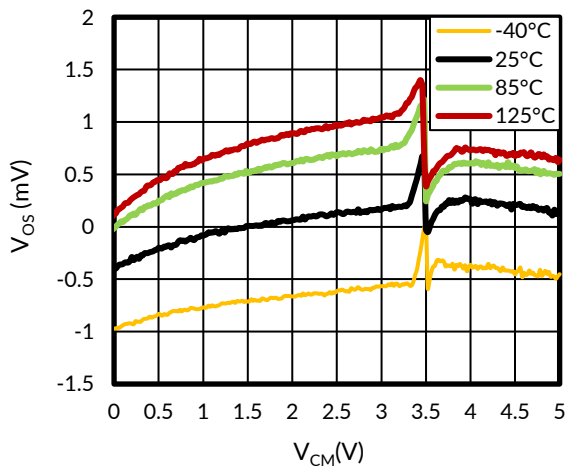

Figure 9. Input Offset Voltage vs Common Mode Voltage

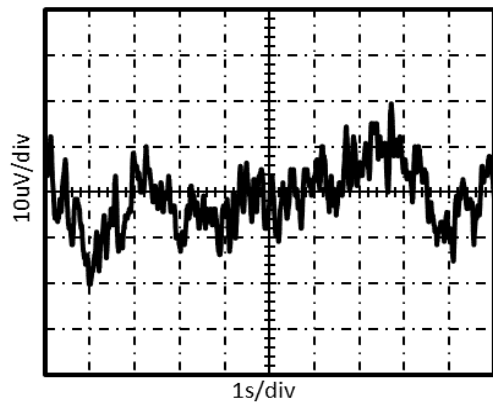

Figure 10. 0.1Hz to 10Hz Noise

8 DETAILED DESCRIPTION

8.1 Overview

The RS876X devices are unity-gain stable, dual and quad-channel op amps with low noise and distortion. The device consists of a low noise input stage with a folded cascade and a rail-to-rail output stage. This topology exhibits superior noise and distortion performance across a wide range of supply voltages that are not delivered by legacy commodity audio operational amplifiers.

8.2 Power On Requirement

For the high-speed amplifier, in order to avoid the bandwidth limit of the input transistors parasitic capacitance, it is generally not large enough, so the offset voltage is larger than the general amplifier. RS876X uses internal calibration circuits to calibrate the offset voltage under high and low common mode conditions, so the typical value of the offset voltage can be 1 mV. The performance is better than most high-speed amplifiers. To ensure the normal calibration function. When using the amplifier, users should pay attention to the high and low VCM switching points, generally near $V_{DD}-1.5V$. To guarantee the calibration block works properly, good power on of the amplifier power supply is recommended:

- Fast power on time to produce the power on reset signal of calibration block. The maximum value of power on time is 1ms.
- Avoid the voltage glitch reaching in 0.4V to 1V range on power supply. For example, power supply drop to 0.5V then recovery to 5V may cause error of calibration block.

If the power on signal is not good, the amplifier has probability to enter an unexpected status.

8.3 Phase Reversal Protection

The RS876X family has internal phase-reversal protection. Many op amps exhibit phase reversal when the input is driven beyond the linear common-mode range. This condition is most often encountered in noninverting circuits when the input is driven beyond the specified common-mode voltage range, causing the output to reverse into the opposite rail. The input of the RS876X prevents phase reversal with excessive common-mode voltage. Instead, the appropriate rail limits the output voltage. This performance is shown in figure 11.

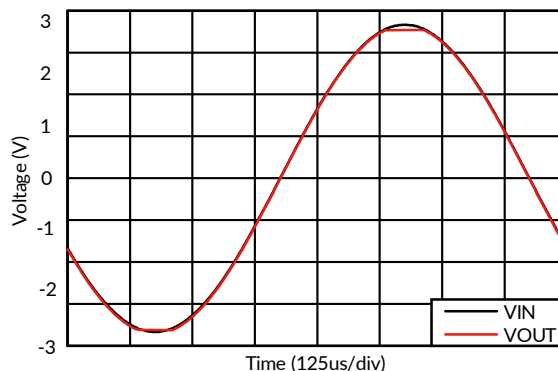

Figure 11. Output Waveform Devoid of Phase Reversal during an Input Overdrive Condition

8.4 Gain Bandwidth Product

For applications that require a gain of +1, no feedback resistor is required. Just short the output pin to the inverting input pin. For gains greater than +1, the feedback resistor forms a pole with the parasitic capacitance at the inverting input. As this pole becomes smaller, the amplifier's phase margin is reduced. This causes ringing in the time domain and peaking in the frequency domain. Therefore, R_F has some maximum value that should not be exceeded for optimum performance. If a large value of R_F must be used, a small capacitor in the few Pico farad range in parallel with R_F can help to reduce the ringing and peaking at the expense of reducing the bandwidth. As far as the output stage of the amplifier is concerned, the output stage is also a gain stage with the load. R_F and R_G appear in parallel with R_L for gains other than +1. As this combination gets smaller, the bandwidth

falls off. Consequently, R_F also has a minimum value that should not be exceeded for optimum performance. For gain of +1, $R_F=0$ is optimum. For the gains other than +1, optimum response is obtained with R_F between 300 Ω to 1K Ω , The RS876X have again bandwidth product of 120MHz. For gains ≥ 5 , its bandwidth can be predicted by the following equation:

$$\text{Gain} \times \text{BW} = 120\text{MHz}$$

8.5 Capacitive Load Driving Capability

RS876X has large output current driving ability and good stability. When the drive output load resistance is 1K Ω and the output capacitor is 40 pF, the frequency response curve peak is less than 5dB. If less peaking is desired in applications, a small series resistor (usually 50 Ω) can be placed in series with the output to eliminate most peaking. However, this will reduce the gain slightly. If the gain setting is greater than 1, the gain resistor R_G can then be chosen to make up for any gain loss which may be created by the additional series resistor at the output. When used as a cable driver, double termination is always recommended for reflection-free performance. For those applications, a back-termination series resistor at the amplifier's output will isolate the amplifier from the cable and allow extensive capacitive drive. However, other applications may have high capacitive loads without a back-termination resistor. Again, a small series resistor at the output can help to reduce peaking.

8.6 Video Performance

For good video performance, an amplifier is required to maintain the same output impedance and the same frequency response as DC levels are changed at the output. This is especially difficult when driving a standard video load of 150 Ω , because the change in output current with DC level. Special circuitry has been incorporated in the RS876X to reduce the variation of the output impedance with the current output. This results in D_g and D_p specifications of 0.03% and 0.3°, while driving 150 Ω at a gain of 2. Driving high impedance loads would give a similar or better D_g and D_p performance.

8.7 Output Drive Capability

The RS8761, RS8762 and RS8764 output stage can supply a continuous output current of $\pm 100\text{mA}$ and still provide approximately 2.7V of output swing on a 5V supply. For maximum reliability, it is not recommended to run a continuous DC current in excess of $\pm 100\text{mA}$. Refer to the typical characteristic curve Output Voltage Swing vs Output Current. For supplying continuous output currents greater than $\pm 100\text{mA}$, the RS876X may be operated in parallel. The RS876X will provide peak currents up to 200mA, which corresponds to the typical short-circuit current.

8.8 Input ESD Diode Protection

The RS876X uses internal electrostatic discharge (ESD) protection circuits on all pins. In the case of input and output pins, this protection primarily consists of current-steering diodes connected between the input and power-supply pins. The following figure shows the schematic diagram of the ESD structure.

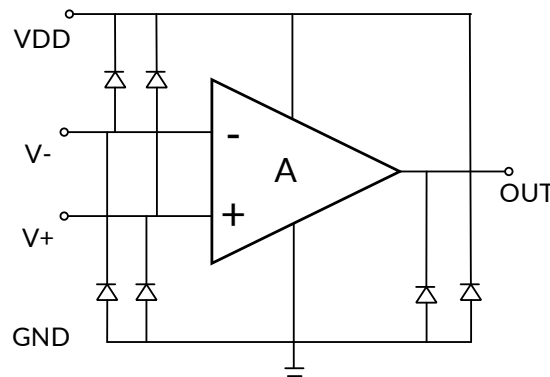

Figure 12. Input ESD Diode

8.9 Power Supply Bypassing and Printed Circuit Board Layout

As with any high frequency device, a good printed circuit board layout is necessary for optimum performance. Lead lengths should be as short as possible. The power supply pin must be well bypassed to reduce the risk of oscillation. For normal single supply operation, where the V_{S-} pin is connected to the ground plane, a single 4.7mF tantalum capacitor in parallel with a 0.1mF ceramic capacitor from V_{S+} to GND will suffice. This same capacitor combination should be placed at each supply pin to ground if split supplies are to be used. In this case, the V_{S-} pin becomes the negative supply rail. For good AC performance, parasitic capacitance should be kept to a minimum. Use of wire wound resistors should be avoided because of their additional series inductance. Use of sockets should also be avoided if possible. Sockets add parasitic inductance and capacitance that can result in compromised performance. Minimizing parasitic capacitance at the amplifier's inverting input pin is very important. The feedback resistor should be placed very close to the inverting input pin. Strip line design techniques are recommended for the signal traces.

9 APPLICATION AND IMPLEMENTATION

Information in the following applications sections is not part of the Runic component specification, and Runic does not warrant its accuracy or completeness. Runic's customers are responsible for determining suitability of components for their purposes. Customers should validate and test their design implementation to confirm system functionality.

9.1 Application Note

The RS8761, RS8762, RS8764 are high precision, rail-to-rail operational amplifiers that can be run from a single-supply voltage 2.7V to 5.5V ($\pm 1.35V$ to $\pm 2.75V$). Supply voltages higher than 7V (absolute maximum) can permanently damage the amplifier. Rail-to-rail output swing significantly increases dynamic range, especially in low-supply applications. Good layout practice mandates use of a 0.1 μF capacitor place closely across the supply pins.

9.2 Single Supply Video Line Driver

The RS8761, RS8762, RS8764 are wide band rail-to-rail output op amplifiers with large output current, excellent Dg, Dp, and low distortion that allow them to drive video signals in low supply applications. Figure below is the single supply non-inverting video line driver configuration and inverting video line driver configuration. The signal is AC coupled by C1. R1 and R2 are used to level shift the input and output to provide the largest output swing. RF and RG set the AC gain. C2 isolates the virtual ground potential. RT and R3 are the termination resistors for the line. C1, C2 and C3 are selected big enough to minimize the drop of the luminance signal.

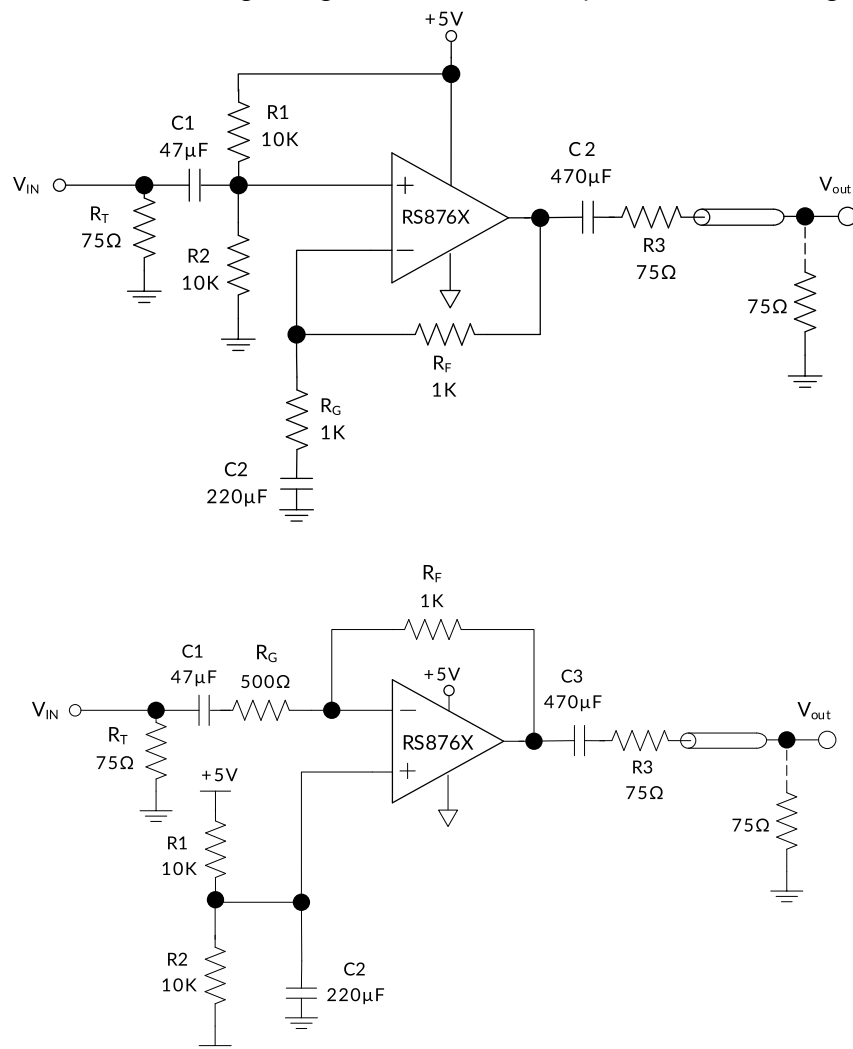
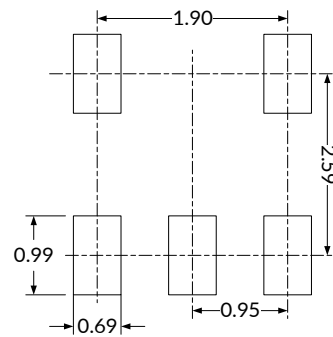
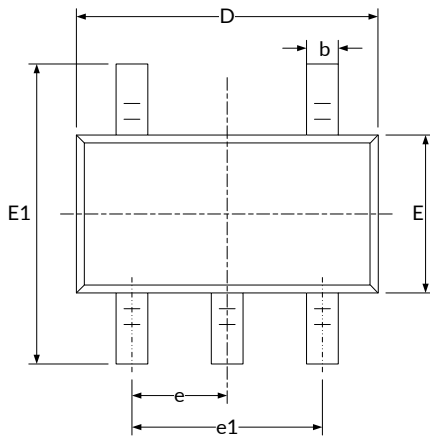

Figure 13. 5V Single Supply Non-Inverting and Inverting Video Line Driver

10 PACKAGE OUTLINE DIMENSIONS

SOT23-5⁽³⁾



RECOMMENDED LAND PATTERN (Unit: mm)

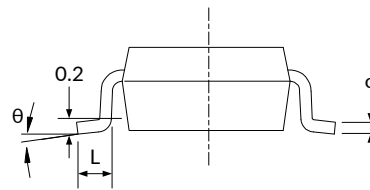
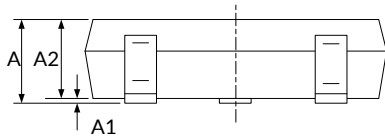

Symbol	Dimensions In Millimeters		Dimensions In Inches	
	Min	Max	Min	Max
A ⁽¹⁾	1.050	1.250	0.041	0.049
A1	0.000	0.100	0.000	0.004
A2	1.050	1.150	0.041	0.045
b	0.300	0.500	0.012	0.020
c	0.100	0.200	0.004	0.008
D ⁽¹⁾	2.820	3.020	0.111	0.119
E ⁽¹⁾	1.500	1.700	0.059	0.067
E1	2.650	2.950	0.104	0.116
e	0.950(BSC) ⁽²⁾		0.037(BSC) ⁽²⁾	
e1	1.800	2.000	0.071	0.079
L	0.300	0.600	0.012	0.024
θ	0°	8°	0°	8°

NOTE:

1. Plastic or metal protrusions of 0.15mm maximum per side are not included.
2. BSC (Basic Spacing between Centers), "Basic" spacing is nominal.
3. This drawing is subject to change without notice.

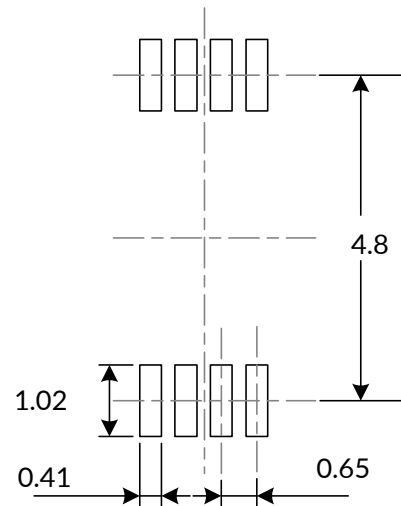
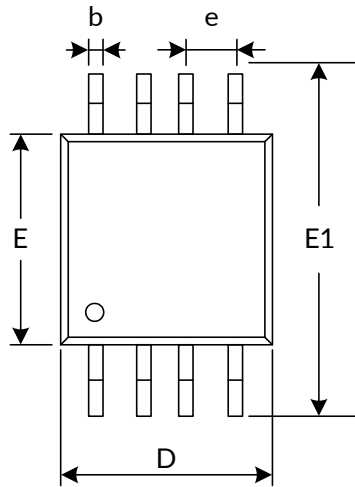
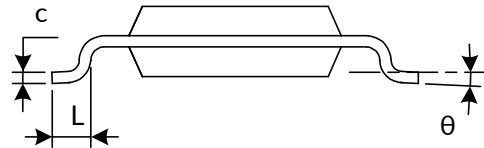
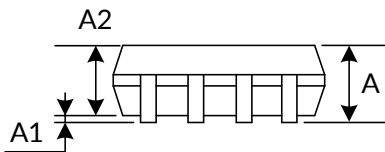
MSOP8⁽³⁾

RECOMMENDED LAND PATTERN (Unit: mm)

Symbol	Dimensions In Millimeters		Dimensions In Inches	
	Min	Max	Min	Max
A ⁽¹⁾	0.820	1.100	0.032	0.043
A1	0.020	0.150	0.001	0.006
A2	0.750	0.950	0.030	0.037
b	0.250	0.380	0.010	0.015
c	0.090	0.230	0.004	0.009
D ⁽¹⁾	2.900	3.100	0.114	0.122
e	0.650(BSC) ⁽²⁾		0.026(BSC) ⁽²⁾	
E ⁽¹⁾	2.900	3.100	0.114	0.122
E1	4.750	5.050	0.187	0.199
L	0.400	0.800	0.016	0.031
θ	0°	6°	0°	6°

NOTE:

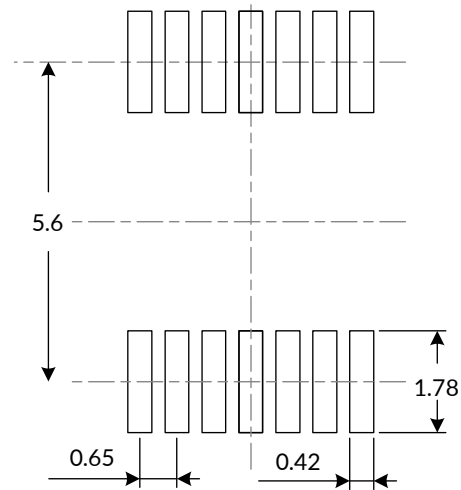
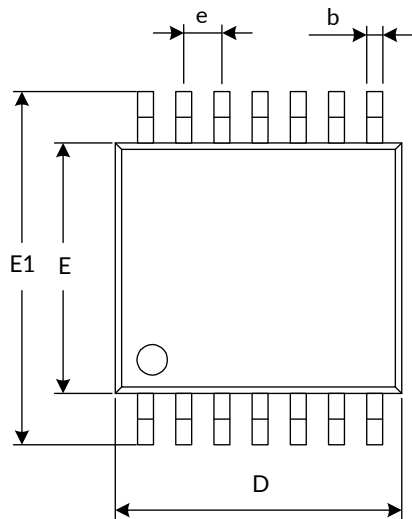
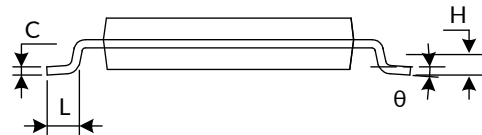
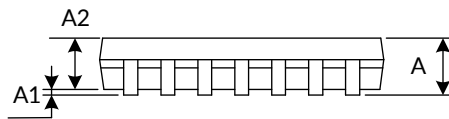
1. Plastic or metal protrusions of 0.15mm maximum per side are not included.
2. BSC (Basic Spacing between Centers), "Basic" spacing is nominal.
3. This drawing is subject to change without notice.

TSSOP14 (3)

RECOMMENDED LAND PATTERN (Unit: mm)

Symbol	Dimensions In Millimeters		Dimensions In Inches	
	Min	Max	Min	Max
A ⁽¹⁾		1.200		0.047
A1	0.050	0.150	0.002	0.006
A2	0.800	1.050	0.031	0.041
b	0.190	0.300	0.007	0.012
c	0.090	0.200	0.004	0.008
D ⁽¹⁾	4.860	5.100	0.191	0.201
E ⁽¹⁾	4.300	4.500	0.169	0.177
E1	6.250	6.550	0.246	0.258
e	0.650(BSC) ⁽²⁾		0.026(BSC) ⁽²⁾	
L	0.500	0.700	0.020	0.028
H	0.25(TYP)		0.01(TYP)	
θ	1°	7°	1°	7°

NOTE:

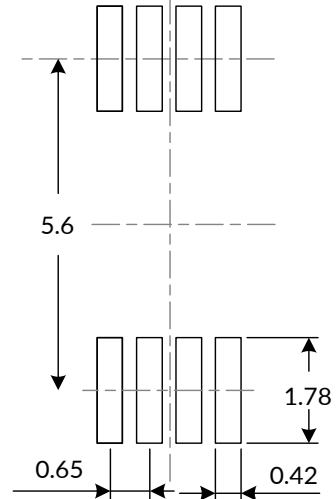
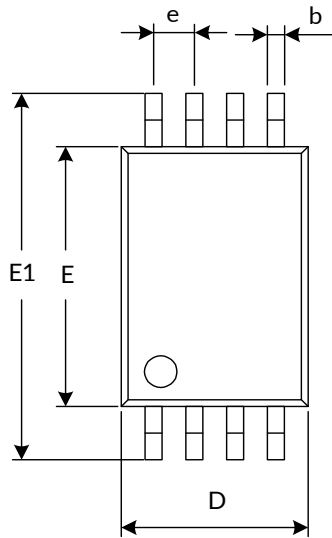
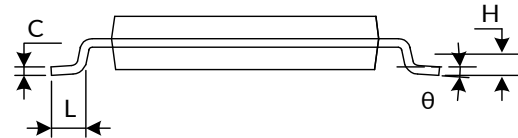
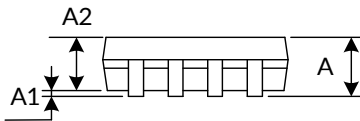
1. Plastic or metal protrusions of 0.15mm maximum per side are not included.
2. BSC (Basic Spacing between Centers), "Basic" spacing is nominal.
3. This drawing is subject to change without notice.

TSSOP8 (3)

RECOMMENDED LAND PATTERN (Unit: mm)

Symbol	Dimensions In Millimeters		Dimensions In Inches	
	Min	Max	Min	Max
A ⁽¹⁾		1.200		0.047
A1	0.050	0.150	0.002	0.006
A2	0.800	1.050	0.031	0.041
b	0.190	0.300	0.007	0.012
c	0.090	0.200	0.004	0.008
D ⁽¹⁾	2.900	3.100	0.114	0.122
E ⁽¹⁾	4.300	4.500	0.169	0.177
E1	6.250	6.550	0.246	0.258
e	0.650(BSC) ⁽²⁾		0.026(BSC) ⁽²⁾	
L	0.500	0.700	0.020	0.028
H	0.25(TYP)		0.01(TYP)	
θ	1°	7°	1°	7°

NOTE:

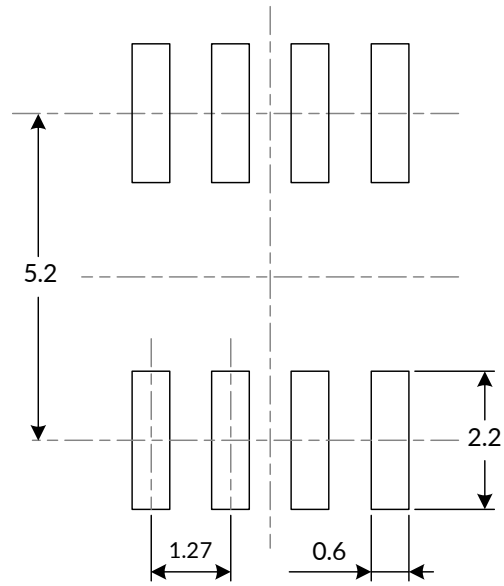
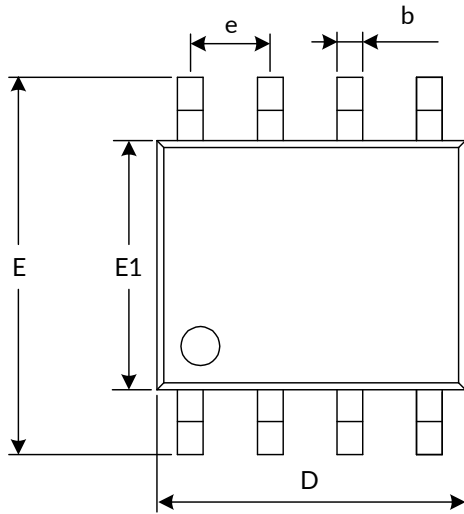
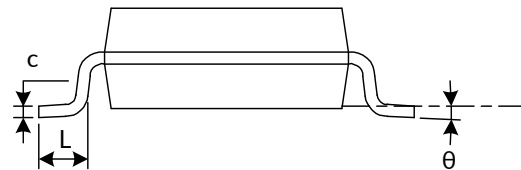
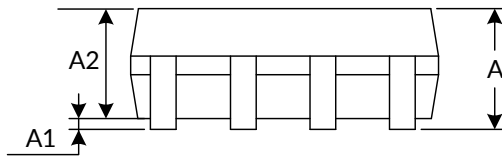
1. Plastic or metal protrusions of 0.15mm maximum per side are not included.
2. BSC (Basic Spacing between Centers), "Basic" spacing is nominal.
3. This drawing is subject to change without notice.

SOP8 (3)

RECOMMENDED LAND PATTERN (Unit: mm)

Symbol	Dimensions In Millimeters		Dimensions In Inches	
	Min	Max	Min	Max
A ⁽¹⁾	1.350	1.750	0.053	0.069
A1	0.100	0.250	0.004	0.010
A2	1.350	1.550	0.053	0.061
b	0.330	0.510	0.013	0.020
c	0.170	0.250	0.007	0.010
D ⁽¹⁾	4.800	5.000	0.189	0.197
e	1.270(BSC) ⁽²⁾		0.050(BSC) ⁽²⁾	
E	5.800	6.200	0.228	0.244
E1 ⁽¹⁾	3.800	4.000	0.150	0.157
L	0.400	1.270	0.016	0.050
θ	0°	8°	0°	8°

NOTE:

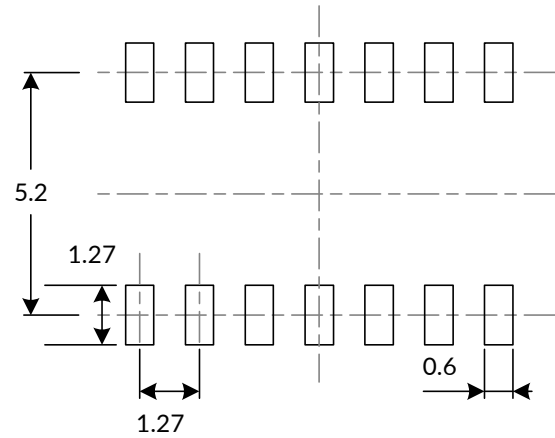
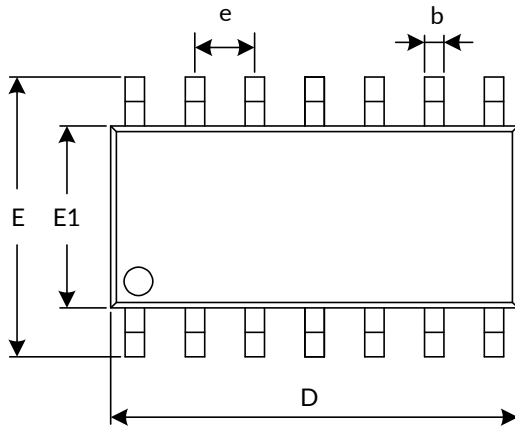
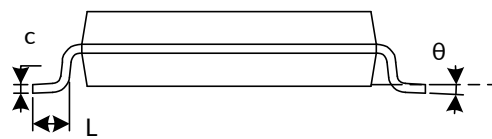
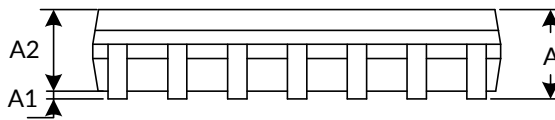
1. Plastic or metal protrusions of 0.15mm maximum per side are not included.
2. BSC (Basic Spacing between Centers), "Basic" spacing is nominal.
3. This drawing is subject to change without notice.

SOP14 (3)

RECOMMENDED LAND PATTERN (Unit: mm)

Symbol	Dimensions In Millimeters		Dimensions In Inches	
	Min	Max	Min	Max
A ⁽¹⁾	1.350	1.750	0.053	0.069
A1	0.100	0.250	0.004	0.010
A2	1.350	1.550	0.053	0.061
b	0.310	0.510	0.012	0.020
c	0.100	0.250	0.004	0.010
D ⁽¹⁾	8.450	8.850	0.333	0.348
e	1.270(BSC) ⁽²⁾		0.050(BSC) ⁽²⁾	
E	5.800	6.200	0.228	0.244
E1 ⁽¹⁾	3.800	4.000	0.150	0.157
L	0.400	1.270	0.016	0.050
θ	0°	8°	0°	8°

NOTE:

1. Plastic or metal protrusions of 0.15mm maximum per side are not included.
2. BSC (Basic Spacing between Centers), "Basic" spacing is nominal.
3. This drawing is subject to change without notice.

11 TAPE AND REEL INFORMATION

REEL DIMENSIONS

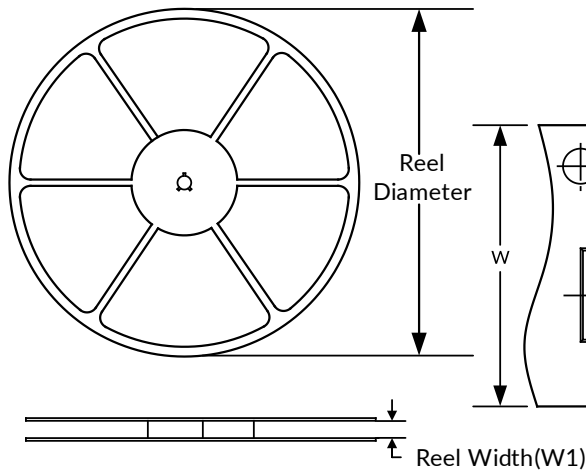

TAPE DIMENSION

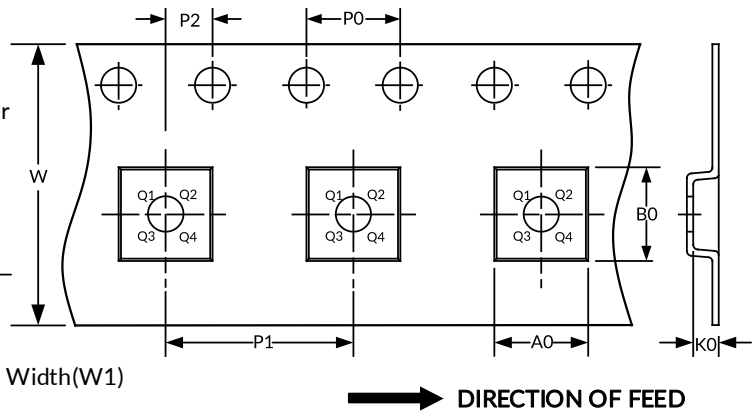

NOTE: The picture is only for reference. Please make the object as the standard.

KEY PARAMETER LIST OF TAPE AND REEL

Package Type	Reel Diameter	Reel Width (mm)	A0 (mm)	B0 (mm)	K0 (mm)	P0 (mm)	P1 (mm)	P2 (mm)	W (mm)	Pin1 Quadrant
SOT23-5	7"	9.5	3.20	3.20	1.40	4.0	4.0	2.0	8.0	Q3
MSOP8	13"	12.4	5.20	3.30	1.50	4.0	8.0	2.0	12.0	Q1
TSSOP14	13"	12.4	6.95	5.60	1.20	4.0	8.0	2.0	12.0	Q1
SOP8	13"	12.4	6.40	5.40	2.10	4.0	8.0	2.0	12.0	Q1
SOP14	13"	16.4	6.60	9.30	2.10	4.0	8.0	2.0	16.0	Q1
TSSOP8	13"	12.4	6.90	3.45	1.65	4.0	8.0	2.0	12.0	Q1

NOTE:

1. All dimensions are nominal.
2. Plastic or metal protrusions of 0.15mm maximum per side are not included.

IMPORTANT NOTICE AND DISCLAIMER

Jiangsu Runic Technology Co., Ltd. will accurately and reliably provide technical and reliability data (including data sheets), design resources (including reference designs), application or other design advice, WEB tools, safety information and other resources, without warranty of any defect, and will not make any express or implied warranty, including but not limited to the warranty of merchantability Implied warranty that it is suitable for a specific purpose or does not infringe the intellectual property rights of any third party.

These resources are intended for skilled developers designing with Runic products You will be solely responsible for: (1) Selecting the appropriate products for your application; (2) Designing, validating and testing your application; (3) Ensuring your application meets applicable standards and any other safety, security or other requirements; (4) Runic and the Runic logo are registered trademarks of Runic Incorporated. All trademarks are the property of their respective owners; (5) For change details, review the revision history included in any revised document. The resources are subject to change without notice. Our company will not be liable for the use of this product and the infringement of patents or third-party intellectual property rights due to its use.