

RS29535 Low-Voltage 16-Bit I²C and SMBus Low-Power I/O Expander with Interrupt Output and Configuration Registers

1 FEATURES

- I²C to Parallel Port Expander
- Wide Power Supply Voltage Range of 1.65V to 5.5V
- Low Standby-Current Consumption
- Open-Drain Active-Low Interrupt Output
- 5V Tolerant I/O Ports
- 400kHz Fast I²C Bus
- Polarity Inversion Register
- Address by Three Hardware Address Pins for Use of up to Eight Devices
- Latched Outputs with High-Current Drive Capability for Directly Driving LEDs
- Latch-Up Performance Exceeds 100mA Per JESD 78, Class II
- ESD Protection Exceeds JESD 22
 - 2000V Human-Body Model (A114-A)
 - 1500V Charged-Device Model (C101)

2 APPLICATIONS

- Servers
- Routers (Telecom Switching Equipment)
- Personal Computers
- Personal Electronics (For Example, Gaming Consoles)
- Industrial Automation
- Products With GPIO-Limited Processors

3 DESCRIPTIONS

The RS29535 is a 24-pin device that provides 16 bits of general purpose parallel input and output (I/O) expansion for the two-line bidirectional I²C bus or (SMBus) protocol. The device can operate with a power supply voltage ranging from 1.65 V to 5.5 V.

The RS29535 consists of two 8-bit Configuration (input or output selection), Input Port, Output Port, and Polarity Inversion (active-high or active-low operation) registers. At power on, the I/Os are configured as inputs. The system master can enable the I/Os as either inputs or outputs by writing to the I/O configuration bits.

The RS29535 does not include the internal I/O pull-up resistor, which requires pull-ups and pull-downs on unused I/O pins when configured as an input and undriven.

Device Information ⁽¹⁾

PART NUMBER	PACKAGE	BODY SIZE (NOM)
RS29535	TSSOP24	7.80mm×4.40mm

(1) For all available packages, see the orderable addendum at the end of the data sheet.

Table of Contents

1 FEATURES	1
2 APPLICATIONS	1
3 DESCRIPTIONS	1
4 REVISION HISTORY	3
5 PACKAGE/ORDERING INFORMATION ⁽¹⁾	4
6 PIN CONFIGURATIONS AND FUNCTIONS	5
7 SPECIFICATIONS	7
7.1 Absolute Maximum Ratings	7
7.2 ESD Ratings	7
7.3 Recommended Operating Conditions	8
7.4 Electrical Characteristics	9
7.5 I ² C Interface Timing Requirements	10
7.6 Switching Characteristics	11
8 PARAMETER MEASUREMENT INFORMATION	12
9 DETAILED DESCRIPTION	15
9.1 Overview	15
9.2 Functional Block Diagram	15
9.3 Feature Description	17
9.3.1 5V Tolerant I/O Ports	17
9.3.2 Hardware Address Pins	17
9.3.3 Interrupt ($\overline{\text{INT}}$) Output	17
9.4 Device Functional Modes	17
9.4.1 Power-On Reset (POR)	17
9.4.2 Powered-Up	17
9.5 Programming	17
9.5.1 I ² C Interface	17
9.5.2 Device Address	21
9.5.3 Control Register and Command Byte	22
9.6 Register Maps	23
9.6.1 Register Descriptions	23
10 APPLICATION AND IMPLEMENTATION	24
10.1 Application Information	24
10.2 Typical Application	24
10.2.1 Design Requirements	25
10.2.2 Detailed Design Procedure	26
11 PACKAGE OUTLINE DIMENSIONS	27
12 TAPE AND REEL INFORMATION	28

4 REVISION HISTORY

Note: Page numbers for previous revisions may differ from page numbers in the current version.

Version	Change Date	Change Item
A.0	2024/07/17	Preliminary version completed
A.1	2025/02/27	Initial version completed

5 PACKAGE/ORDERING INFORMATION ⁽¹⁾

PRODUCT	ORDERING NUMBER	TEMPERATURE RANGE	PACKAGE LEAD	PACKAGE MARKING ⁽²⁾	MSL ⁽³⁾	PACKAGE OPTION
RS29535	RS29535XTSS24	-40°C ~125°C	TSSOP24	RS29535	MSL3	Tape and Reel, 4000

NOTE:

- (1) This information is the most current data available for the designated devices. This data is subject to change without notice and revision of this document. For browser-based versions of this data sheet, refer to the right-hand navigation.
- (2) There may be additional marking, which relates to the lot trace code information (data code and vendor code), the logo or the environmental category on the device.
- (3) Runic classify the MSL level with using the common preconditioning setting in our assembly factory conforming to the JEDEC industrial standard J-STD-20F, Please align with Runic if your end application is quite critical to the preconditioning setting or if you have special requirement.

6 PIN CONFIGURATIONS AND FUNCTIONS

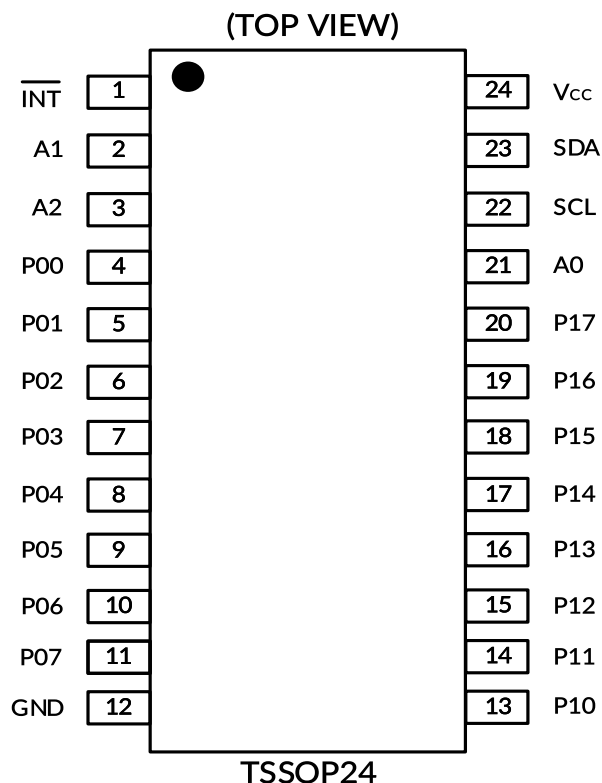

PIN DESCRIPTION

PIN	NAME	TYPE ⁽²⁾	DESCRIPTION
TSSOP24			
21	A0	I	Address input 0. Connect directly to V _{CC} or ground
2	A1	I	Address input 1. Connect directly to V _{CC} or ground
3	A2	I	Address input 2. Connect directly to V _{CC} or ground
12	GND	–	Ground
1	$\overline{\text{INT}}$	O	Interrupt output. Connect to V _{CC} through an external pull-up resistor
4	P00 ⁽¹⁾	I/O	P-port I/O. Push-pull design structure. At power on, P00 is configured as an input
5	P01 ⁽¹⁾	I/O	P-port I/O. Push-pull design structure. At power on, P01 is configured as an input
6	P02 ⁽¹⁾	I/O	P-port I/O. Push-pull design structure. At power on, P02 is configured as an input
7	P03 ⁽¹⁾	I/O	P-port I/O. Push-pull design structure. At power on, P03 is configured as an input
8	P04 ⁽¹⁾	I/O	P-port I/O. Push-pull design structure. At power on, P04 is configured as an input
9	P05 ⁽¹⁾	I/O	P-port I/O. Push-pull design structure. At power on, P05 is configured as an input
10	P06 ⁽¹⁾	I/O	P-port I/O. Push-pull design structure. At power on, P06 is configured as an input
11	P07 ⁽¹⁾	I/O	P-port I/O. Push-pull design structure. At power on, P07 is configured as an input

13	P10 ⁽¹⁾	I/O	P-port I/O. Push-pull design structure. At power on, P10 is configured as an input
14	P11 ⁽¹⁾	I/O	P-port I/O. Push-pull design structure. At power on, P11 is configured as an input
15	P12 ⁽¹⁾	I/O	P-port I/O. Push-pull design structure. At power on, P12 is configured as an input
16	P13 ⁽¹⁾	I/O	P-port I/O. Push-pull design structure. At power on, P13 is configured as an input
17	P14 ⁽¹⁾	I/O	P-port I/O. Push-pull design structure. At power on, P14 is configured as an input
18	P15 ⁽¹⁾	I/O	P-port I/O. Push-pull design structure. At power on, P15 is configured as an input
19	P16 ⁽¹⁾	I/O	P-port I/O. Push-pull design structure. At power on, P16 is configured as an input
20	P17 ⁽¹⁾	I/O	P-port I/O. Push-pull design structure. At power on, P17 is configured as an input
22	SCL	I	Serial clock bus. Connect to V _{CC} through a pull-up resistor
23	SDA	I	Serial data bus. Connect to V _{CC} through a pull-up resistor
24	V _{CC}	—	Supply voltage

(1) If port is unused, it must be tied to either V_{CC} or GND through a resistor of moderate value (about 10kΩ).

(2) I=input, O=output, I/O=input and output.

7 SPECIFICATIONS

7.1 Absolute Maximum Ratings

over operating free-air temperature range (unless otherwise noted) ⁽¹⁾

SYMBOL	PARAMETER		MIN	MAX	UNIT
V _{CC}	Supply Voltage		-0.5	6.5	V
V _I	Input voltage ⁽²⁾		-0.5	6.5	V
V _O	Output voltage ⁽²⁾		-0.5	6.5	V
I _{IK}	Input clamp current	V _I < 0		-20	mA
I _{OK}	Output clamp current	V _O < 0		-20	mA
I _{IOK}	Input-output clamp current	V _O < 0 or V _O > V _{CC}		±20	mA
I _{OL}	Continuous output low current	V _O = 0 to V _{CC}		50	mA
I _{OH}	Continuous output high current	V _O = 0 to V _{CC}		-50	mA
I _{CC}	Continuous current through GND			-250	mA
	Continuous current through V _{CC}			160	mA
θ _{JA}	Package thermal impedance ⁽³⁾	TSSOP24		35	°C/W
T _J	Junction Temperature ⁽⁴⁾			100	°C
T _{stg}	Storage temperature		-65	150	

(1) Stresses beyond those listed under Absolute Maximum Ratings may cause permanent damage to the device. These are stress ratings only, which do not imply functional operation of the device at these or any other conditions beyond those indicated under Recommended Operating Conditions. Exposure to absolute-maximum-rated conditions for extended periods may affect device reliability.

(2) The input negative-voltage and output voltage ratings may be exceeded if the input and output current ratings are observed.

(3) The package thermal impedance is calculated in accordance with JESD-51.

(4) The maximum power dissipation is a function of T_{J(MAX)}, R_{θJA}, and T_A. The maximum allowable power dissipation at any ambient temperature is P_D = (T_{J(MAX)} - T_A) / R_{θJA}. All numbers apply for packages soldered directly onto a PCB.

7.2 ESD Ratings

The following ESD information is provided for handling of ESD-sensitive devices in an ESD protected area only.

			VALUE	UNIT
V _(ESD)	Electrostatic discharge	Human-Body Model (HBM)	±2000	V
		Charged-Device Model (CDM)	±1000	V



ESD SENSITIVITY CAUTION

ESD damage can range from subtle performance degradation to complete device failure. Precision integrated circuits may be more susceptible to damage because very small parametric changes could cause the device not to meet its published specifications.

7.3 Recommended Operating Conditions

over operating free-air temperature range (unless otherwise noted).

PARAMETER		CONDITIONS		MIN	MAX	UNIT
V _{CC}	Supply voltage			1.65	5.5	V
V _{IH}	High-level input voltage	SCL, SDA		0.7 × V _{CC}	V _{CC} ⁽¹⁾	V
		A2-A0, P07-P00, P17-P10		0.7 × V _{CC}	5.5	
V _{IL}	Low-level input voltage	SCL, SDA, A2-A0, P07-P00, P17-P10		-0.5	0.3 × V _{CC}	V
I _{OH}	High-level output current	P07-P00, P17-P10			-10	mA
I _{OL}	Low-level output current ⁽²⁾	P07-P00, P17-P10	T _J ≤ 65°C		25	mA
			T _J ≤ 85°C		18	
			T _J ≤ 100°C		11	
I _{OL}	Low-level output current ⁽²⁾	$\overline{\text{INT}}$, SDA	T _J ≤ 85°C		6	mA
			T _J ≤ 100°C		3.5	
T _A	Operating free-air temperature			-40	125	°C

(1) For voltages applied above V_{CC}, an increase in I_{CC} results.

(2) The values shown apply to specific junction temperatures, which depend on the R_{θJA} of the package used. See the Calculating Junction Temperature and Power Dissipation section on how to calculate the junction temperature.

7.4 Electrical Characteristics

over recommended operating free-air temperature range (unless otherwise noted)

PARAMETER		TEST CONDITIONS	V _{CC}	MIN	TYP ⁽¹⁾	MAX	UNIT		
V _{IK}	Input diode clamp voltage	I _I = -18 mA	1.65 V to 5.5 V	-1.2			V		
V _{OH}	P-port high-level output voltage ⁽²⁾	I _{OH} = -8 mA	1.65 V	1.2			V		
			2.3 V	1.8					
			3 V	2.6					
			4.75 V	4.1					
		I _{OH} = -10 mA	1.65 V	1					
			2.3 V	1.7					
			3 V	2.5					
			4.75 V	4					
I _{OL}	Low-level output current	SDA	V _{OL} = 0.4 V	1.65 V to 5.5 V	3		mA		
		P port ⁽³⁾	V _{OL} = 0.5 V	1.65 V to 5.5 V	8				
			V _{OL} = 0.7 V	1.65 V to 5.5 V	10				
		INT	V _{OL} = 0.4 V	1.65 V to 5.5 V	3				
I _I	Input leakage current	SCL, SDA Input leakage	V _I = V _{CC} or GND	1.65 V to 5.5 V		±1	μA		
		A2-A0 Input leakage	V _I = V _{CC} or GND	1.65 V to 5.5 V		±1			
I _{IH}	Input high leakage current	P port	V _I = V _{CC}	1.65 V to 5.5 V		1	μA		
I _{IL}	Input low leakage current	P port	V _I = GND	1.65 V to 5.5 V		-1	μA		
I _{CC}	Quiescent current	Operating mode	V _I = V _{CC} or GND, I _O = 0, I/O = inputs, f _{SCL} = 400 kHz, No load	5.5 V			75	μA	
				3.6 V			39		
				2.7 V			26		
				1.95 V			17		
				1.65 V			15		
		Standby mode	V _I = V _{CC} , I _O = 0, I/O = inputs, f _{SCL} = 0 kHz, No load	5.5 V		1.5	3.9		
				3.6 V		0.9	2.2		
				2.7 V		0.6	1.8		
				1.95 V		0.6	1.5		
				V _I = GND, I _O = 0, I/O = inputs, f _{SCL} = 0 kHz, No load	5.5 V		1.5		8.7
					3.6 V		0.9		4
					2.7 V		0.6		3
1.95 V		0.4	2.2						
C _I	Input capacitance	SCL	V _I = V _{CC} or GND	1.65 V to 5.5 V		3	8	pF	
C _{io}	Input-output pin capacitance	SDA	V _{IO} = V _{CC} or GND	1.65 V to 5.5 V		3	9.5	pF	
		P port	V _{IO} = V _{CC} or GND	1.65 V to 5.5 V		3.7	9.5		

(1) All typical values are at nominal supply voltage (1.8V, 2.5V, 3.3V, or 5V V_{CC}) and T_A = 25°C.

(2) Each I/O must be externally limited to a maximum of 25 mA, and each octal (P07-P00 and P17-P10) must be limited to a maximum current of 100 mA, for a device total of 200 mA.

(3) The total current sourced by all I/Os must be limited to 160 mA (80 mA for P07-P00 and 80 mA for P17-P10).

7.5 I²C Interface Timing Requirements

over recommended operating free-air temperature range (unless otherwise noted)

		MIN	MAX	UNIT
I²C BUS—STANDARD MODE				
f _{scl}	I ² C clock frequency	0	100	kHz
t _{sch}	I ² C clock high time	4		μs
t _{scl}	I ² C clock low time	4.7		μs
t _{sp}	I ² C spike time		50	ns
t _{sds}	I ² C serial-data setup time	250		ns
t _{sdh}	I ² C serial-data hold time	0		ns
t _{icr}	I ² C input rise time		1000	ns
t _{icf}	I ² C input fall time		300	ns
t _{ocf}	I ² C output fall time	10pF to 400pF bus	300	ns
t _{buf}	I ² C bus free time between stop and start	4.7		μs
t _{sts}	I ² C start or repeated start condition setup	4.7		μs
t _{sth}	I ² C start or repeated start condition hold	4		μs
t _{sps}	I ² C stop condition setup	4		μs
t _{vd(data)}	Valid data time	SCL low to SDA output valid	3.45	μs
t _{vd(ack)}	Valid data time of ACK condition	ACK signal from SCL low to SDA (out) low	3.45	μs
C _b	I ² C bus capacitive load		400	pF
I²C BUS—FAST MODE				
f _{scl}	I ² C clock frequency	0	400	kHz
t _{sch}	I ² C clock high time	0.6		μs
t _{scl}	I ² C clock low time	1.3		μs
t _{sp}	I ² C spike time		50	ns
t _{sds}	I ² C serial-data setup time	100		ns
t _{sdh}	I ² C serial-data hold time	0		ns
t _{icr}	I ² C input rise time	20	300	ns
t _{icf}	I ² C input fall time	20 × (V _{CC} /5.5V)	300	ns
t _{ocf}	I ² C output fall time	10pF to 400pF bus	20 × (V _{CC} /5.5V)	ns
t _{buf}	I ² C bus free time between stop and start	1.3		μs
t _{sts}	I ² C start or repeated start condition setup	0.6		μs
t _{sth}	I ² C start or repeated start condition hold	0.6		μs
t _{sps}	I ² C stop condition setup	0.6		μs
t _{vd(data)}	Valid data time	SCL low to SDA output valid	0.9	μs
t _{vd(ack)}	Valid data time of ACK condition	ACK signal from SCL low to SDA (out) low	0.9	μs
C _b	I ² C bus capacitive load		400	pF

7.6 Switching Characteristics

over recommended operating free-air temperature range, $C_L \leq 100$ pF (unless otherwise noted) ⁽¹⁾

PARAMETER		FROM (INPUT)	TO (OUTPUT)	MIN	MAX	UNIT
t_{iv}	Interrupt valid time	P port	\overline{INT}		4	μ s
t_{ir}	Interrupt reset delay time	SCL	\overline{INT}		4	μ s
t_{pv}	Output data valid; For $V_{CC} = 2.3$ V–5.5 V	SCL	P port		200	ns
	Output data valid; For $V_{CC} = 1.65$ V–2.3 V				300	ns
t_{ps}	Input data setup time	P port	SCL	150		ns
t_{ph}	Input data hold time	P port	SCL	1		μ s

(1) This parameter is ensured by design and/or characterization and is not tested in production.

8 PARAMETER MEASUREMENT INFORMATION

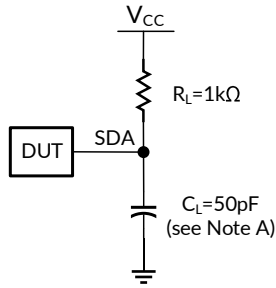

SDA LOAD CONFIGURATION

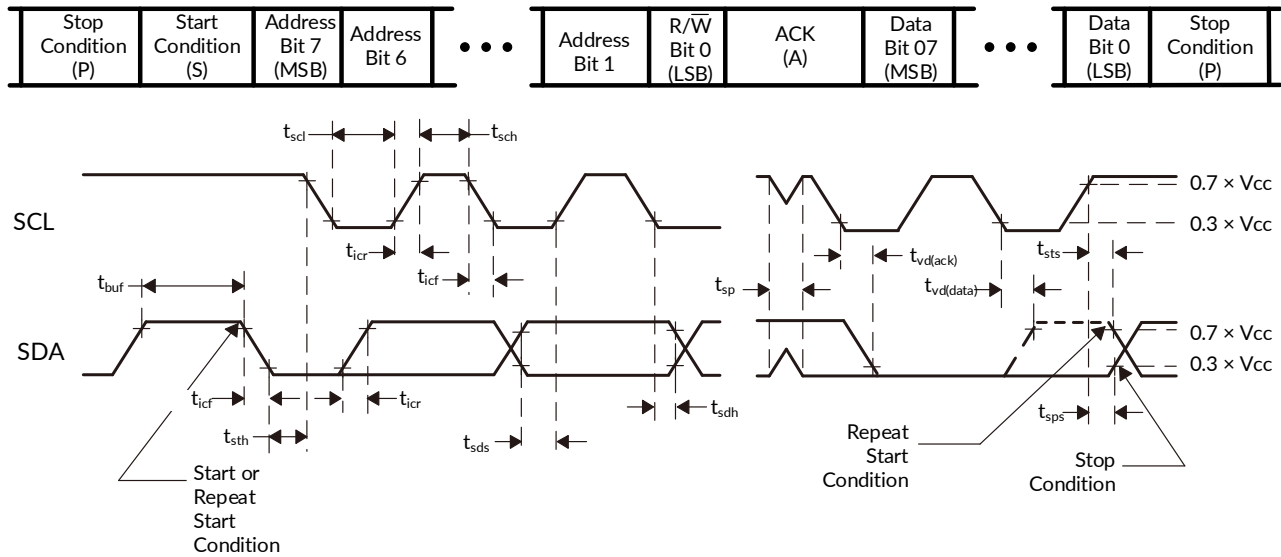

VOLTAGE WAVEFORMS

BYTE	DESCRIPTION
1	I ² C address
2, 3	P-port data

- A. C_L includes probe and jig capacitance.
- B. All inputs are supplied by generators having the following characteristics: $PRR \leq 10 \text{ MHz}$, $Z_o = 50 \Omega$, $t_r/t_f \leq 30 \text{ ns}$.
- C. All parameters and waveforms are not applicable to all devices.

Figure 1. I²C Interface Load Circuit and Voltage Waveforms

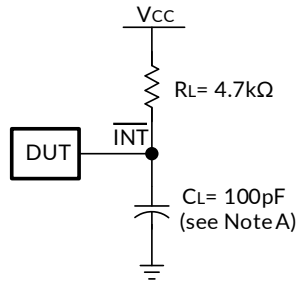

Interrupt Load Configuration

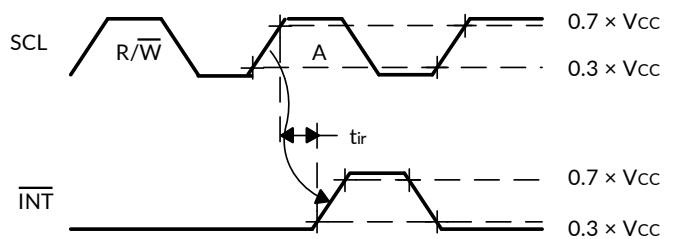
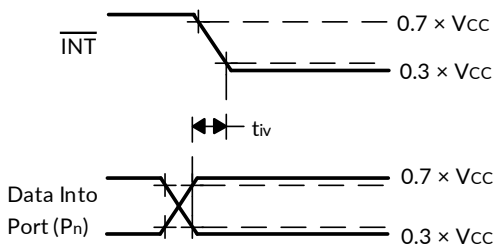
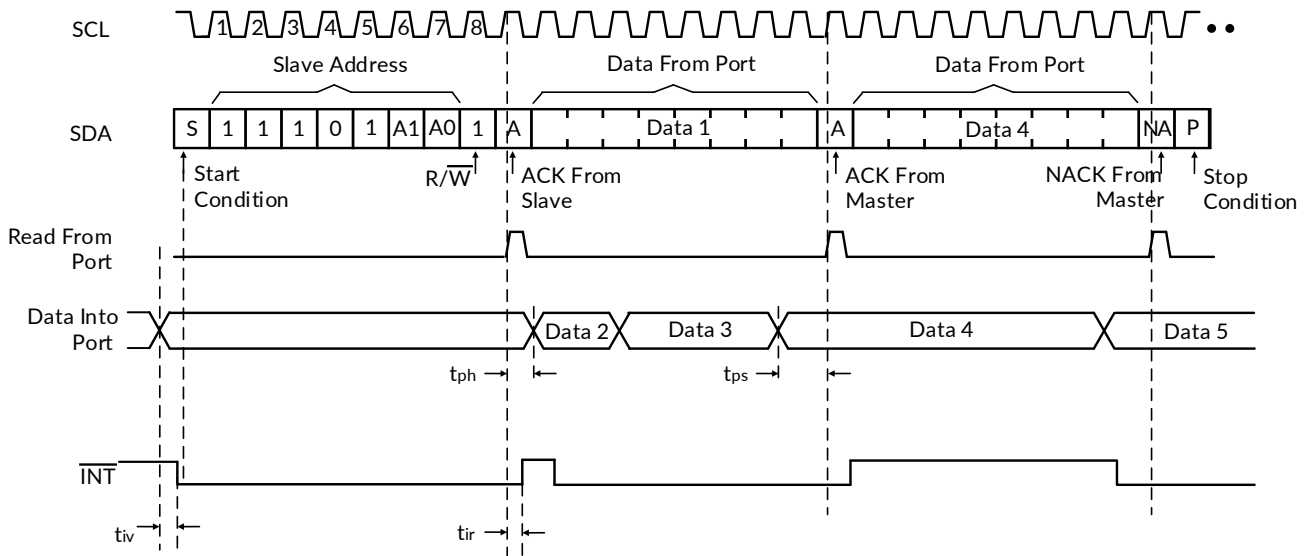

- A. C_L includes probe and jig capacitance.
- B. All inputs are supplied by generators having the following characteristics: $PRR \leq 10 \text{ MHz}$, $Z_O = 50 \Omega$, $t_r / t_f \leq 30 \text{ ns}$.
- C. All parameters and waveforms are not applicable to all devices.

Figure 2. Interrupt Load Circuit and Voltage Waveforms

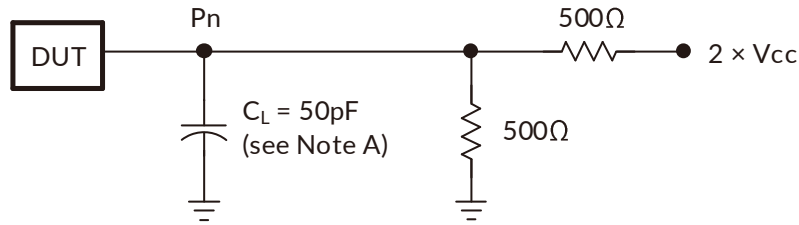

P-Port Load Configuration

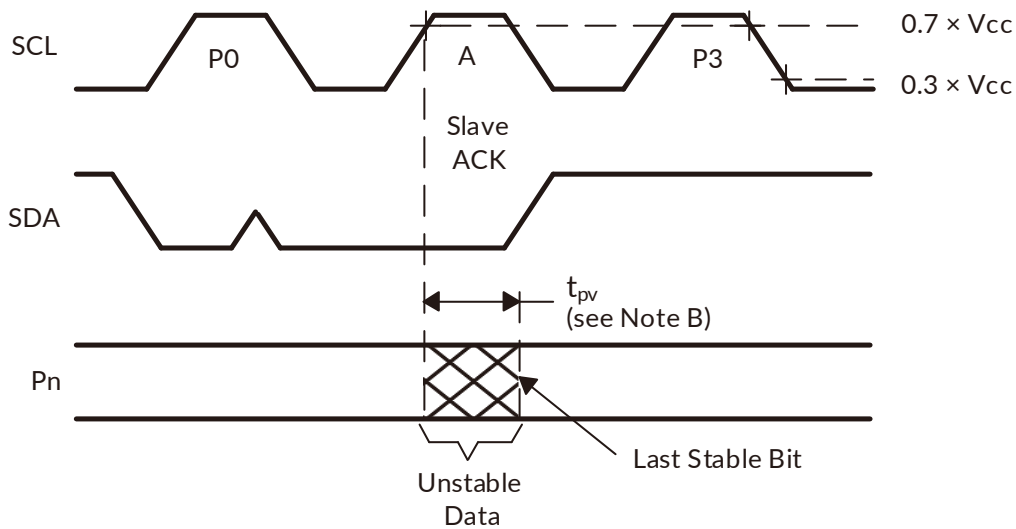

Write Mode ($R/\bar{W} = 0$)

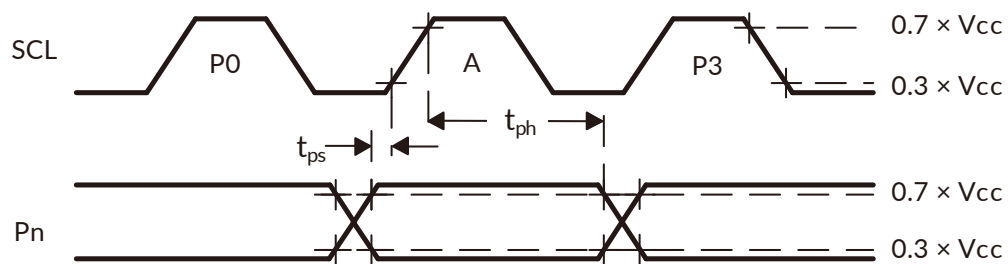

Read Mode ($R/\bar{W} = 1$)

- A. C_L includes probe and jig capacitance.
- B. t_{pv} is measured from $0.7 \times V_{CC}$ on SCL to 50% I/O (Pn) output.
- C. All inputs are supplied by generators having the following characteristics: PRR ≤ 10 MHz, $Z_o = 50 \Omega$, $t_r / t_f \leq 30$ ns.
- D. The outputs are measured one at a time, with one transition per measurement.
- E. All parameters and waveforms are not applicable to all devices.

Figure 3. P-Port Load Circuit and Voltage Waveforms

9 DETAILED DESCRIPTION

9.1 Overview

The RS29535 device is a 16-bit I/O expander for the I²C bus and is designed for 1.65V to 5.5V V_{CC} operation. It provides general-purpose remote I/O expansion for most microcontroller families via the I²C interface.

The RS29535 consists of two 8-bit Configuration (input or output selection), Input Port, Output Port, and Polarity Inversion (active-high or active-low operation) registers. At power-on, the I/Os are configured as inputs. The system master can enable the I/Os as either inputs or outputs by writing to the I/O configuration register bits. The data for each input or output is kept in the corresponding Input or output register. The polarity of the Input Port register can be inverted with the Polarity Inversion register. All registers can be read by the system master. The RS29535 open-drain interrupt ($\overline{\text{INT}}$) output is activated when any input state differs from its corresponding Input Port register state and is used to indicate to the system master that an input state has changed.

$\overline{\text{INT}}$ can be connected to the interrupt input of a microcontroller. By sending an interrupt signal on this line, the remote I/O can inform the microcontroller if there is incoming data on its ports without having to communicate via the I²C bus. Thus, the RS29535 can remain a simple slave device.

The device outputs (latched) have high-current drive capability for directly driving LEDs. The device has low current consumption.

The RS29535 device is similar to the RS29555, except for the removal of the internal I/O pull-up resistor, which greatly reduces power consumption when the I/Os are held low.

Three hardware pins (A0, A1 and A2) are used to program and vary the fixed I²C address and allow up to 8 devices to share the same I²C bus or SMBus.

9.2 Functional Block Diagram

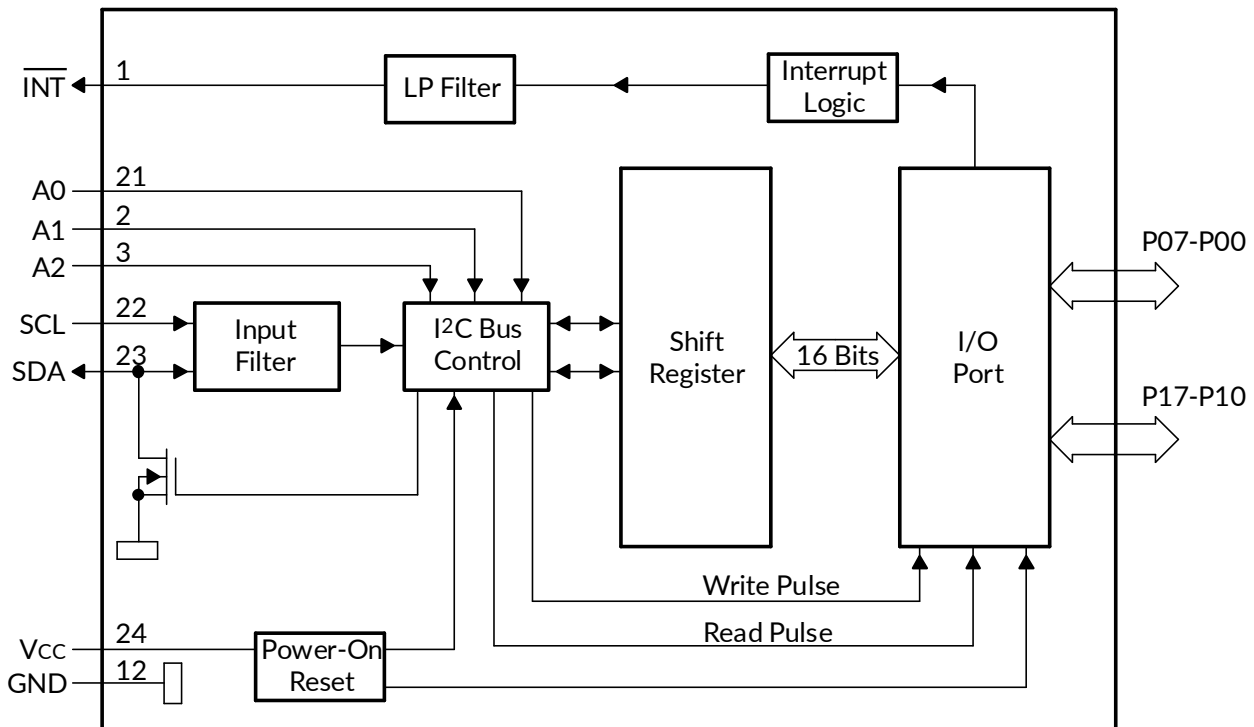

Pin numbers shown are for the TSSOP24 package.

All I/Os are set to inputs at reset.

Figure 4. Logic Diagram (Positive Logic)

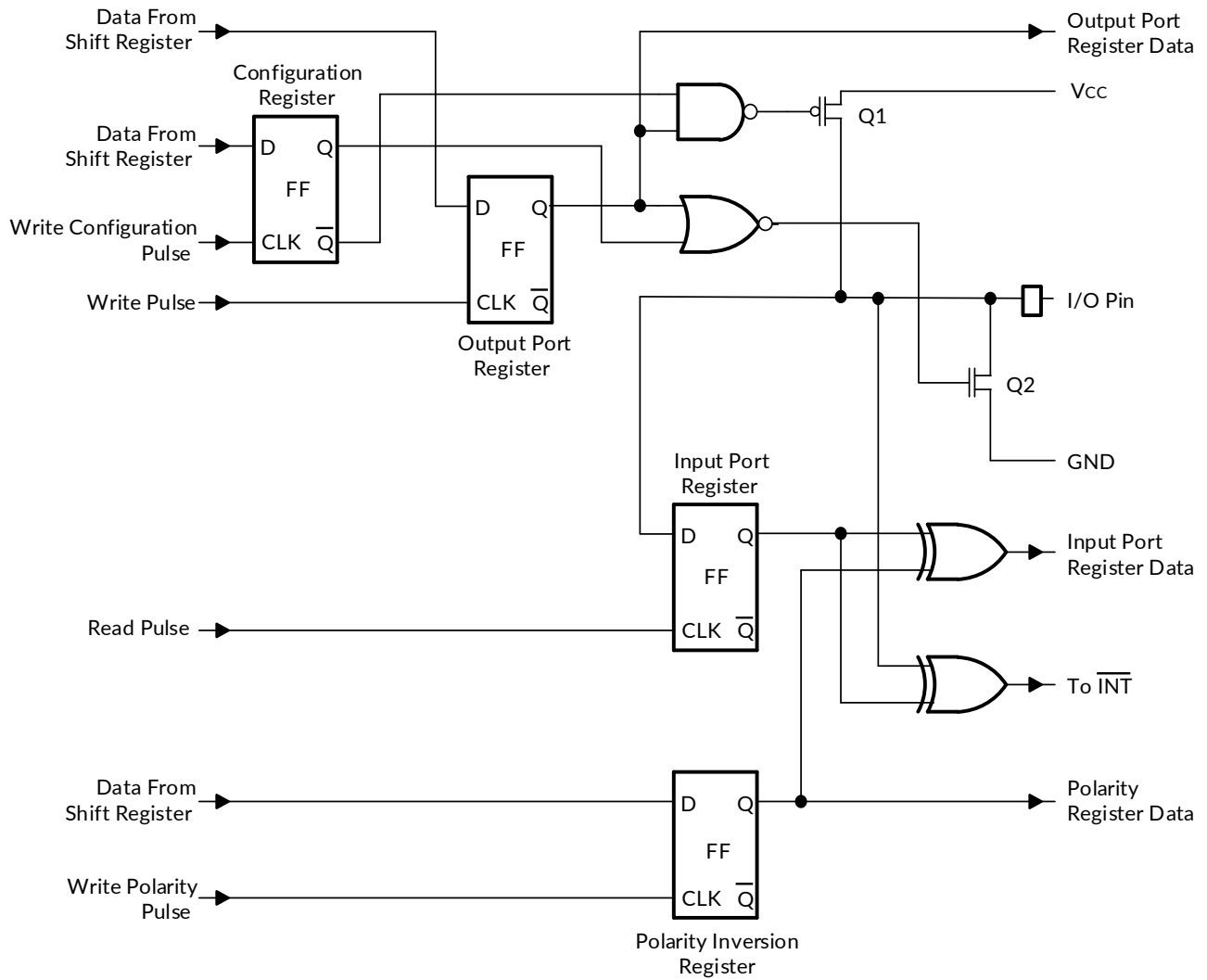

At power-on reset, all registers return to default values.

Figure 5. Simplified Schematic of P-Port I/Os

9.3 Feature Description

9.3.1 5V Tolerant I/O Ports

The RS29535 device features I/O ports, which are tolerant of up to 5V. This allows the RS29535 to be connected to a large array of devices. To minimize I_{CC} , any input signals must be designed so that the input voltage stays within V_{IH} and V_{IL} of the device as described in the Electrical Characteristics section.

9.3.2 Hardware Address Pins

The RS29535 features 3 hardware address pins (A0, A1, and A2) to allow the user to select the device's I²C address by pulling each pin to either V_{CC} or GND to signify the bit value in the address. This allows up to 8 RS29535 devices to be on the same bus without address conflicts. See the Functional Block Diagram to see the 3 address pins. The voltage on the pins must not change while the device is powered up in order to prevent possible I²C glitches as a result of the device address changing during a transmission. All of the pins must be tied either to V_{CC} or GND and cannot be left floating.

9.3.3 Interrupt (\overline{INT}) Output

An interrupt is generated by any rising or falling edge of the port inputs in the input mode. After time t_{IV} , the signal \overline{INT} is valid. Resetting the interrupt circuit is achieved when data on the port is changed to the original setting or data is read from the port that generated the interrupt. Resetting occurs in the read mode at the acknowledge (ACK) bit after the rising edge of the SCL signal. Note that the \overline{INT} is reset at the ACK just before the byte of changed data is sent. Interrupts that occur during the ACK clock pulse can be lost (or be very short) because of the resetting of the interrupt during this pulse. Each change of the I/Os after resetting is detected and is transmitted as \overline{INT} .

Reading from or writing to another device does not affect the interrupt circuit, and a pin configured as an output cannot cause an interrupt. Changing an I/O from an output to an input may cause a false interrupt to occur if the state of the pin does not match the contents of the Input Port register. Because each 8-bit port is read independently, the interrupt caused by port 0 is not cleared by a read of port 1, or vice versa.

\overline{INT} has an open-drain structure and requires a pull-up resistor to V_{CC} of moderate value (typically about 10k Ω).

9.4 Device Functional Modes

9.4.1 Power-On Reset (POR)

When power (from 0V) is applied to V_{CC} , an internal power-on reset circuit holds the RS29535 in a reset condition until V_{CC} has reached V_{PORR} . At that time, the reset condition is released, and the RS29535 registers and I²C-SMBus state machine initialize to their default states. After that, V_{CC} must be lowered to below V_{PORF} and back up to the operating voltage for a power-reset cycle.

9.4.2 Powered-Up

When power has been applied to V_{CC} above V_{PORR} , and the POR has taken place, the device is in a functioning mode. In this state, the device is ready to accept any incoming I²C requests and is monitoring for changes on the input ports.

9.5 Programming

9.5.1 I²C Interface

The RS29535 has a standard bidirectional I²C interface that is controlled by a master device in order to be configured or read the status of this device. Each slave on the I²C bus has a specific device address to differentiate between other slave devices that are on the same I²C bus. Many slave devices require configuration upon startup to set the behavior of the device. This is typically done when the master accesses internal register maps of the slave, which have unique register addresses. A device can have one or multiple registers where data is stored, written, or read.

The physical I²C interface consists of the serial clock (SCL) and serial data (SDA) lines. Both SDA and SCL lines must be connected to V_{CC} through a pull-up resistor. The size of the pull-up resistor is determined by the amount

of capacitance on the I²C lines. Data transfer may be initiated only when the bus is idle. A bus is considered idle if both SDA and SCL lines are high after a STOP condition. See Table 1.

Figure 6 and Figure 7 show the general procedure for a master to access a slave device:

1. If a master wants to send data to a slave:
 - Master-transmitter sends a START condition and addresses the slave-receiver.
 - Master-transmitter sends data to slave-receiver.
 - Master-transmitter terminates the transfer with a STOP condition.
2. If a master wants to receive or read data from a slave:
 - Master-receiver sends a START condition and addresses the slave-transmitter.
 - Master-receiver sends the requested register to read to slave-transmitter.
 - Master-receiver receives data from the slave-transmitter.
 - Master-receiver terminates the transfer with a STOP condition.

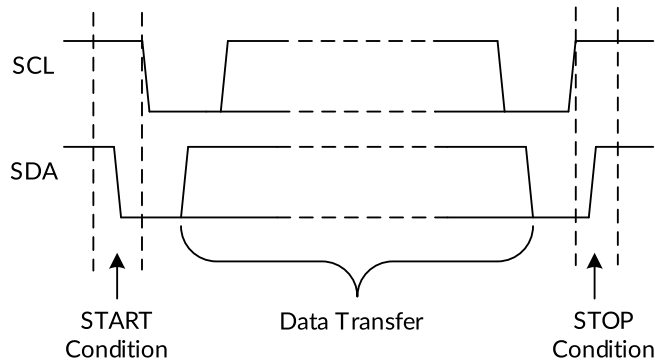

Figure 6. Definition of Start and Stop Conditions

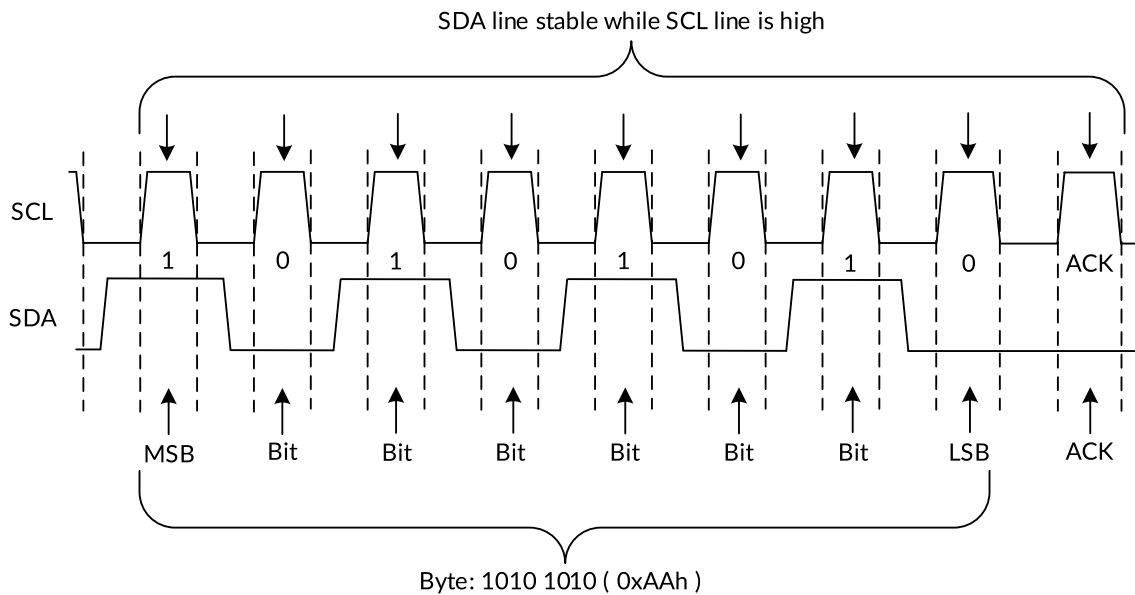

Figure 7. Bit Transfer

Table 1 shows the interface definition.

Table 1. Interface Definition

BYTE	BIT							
	7 (MSB)	6	5	4	3	2	1	0 (LSB)
I ² C slave address	L	H	L	L	A2	A1	A0	R/ \bar{W}
P0x I/O data bus	P07	P06	P05	P04	P03	P02	P01	P00
P1x I/O data bus	P17	P16	P15	P14	P13	P12	P11	P10

9.5.1.1 Bus Transactions

Data is exchanged between the master and the RS29535 through write and read commands, and this is accomplished by reading from or writing to registers in the slave device.

Registers are locations in the memory of the slave which contain information, whether it be the configuration information or some sampled data to send back to the master. The master must write information to these registers in order to instruct the slave device to perform a task.

9.5.1.1.1 Writes

To write on the I²C bus, the master sends a START condition on the bus with the address of the slave, as well as the last bit (the R/W bit) set to 0, which signifies a write. After the slave sends the acknowledge bit, the master then sends the register address of the register to which it wishes to write. The slave acknowledges again, letting the master know it is ready. After this, the master starts sending the register data to the slave until the master has sent all the data necessary (which is sometimes only a single byte), and the master terminates the transmission with a STOP condition.

See the Control Register and Command Byte section to see list of the RS29535's internal registers and a description of each one.

Figure 8 shows an example of writing a single byte to a slave register.

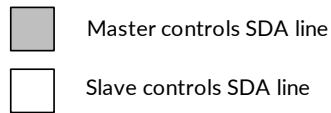

Write to one register in a device

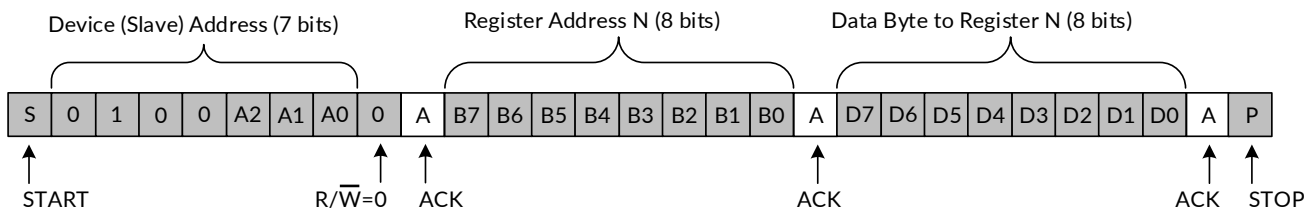

Figure 8. Write to Register

Figure 9 shows the Write to the Polarity Inversion Register.

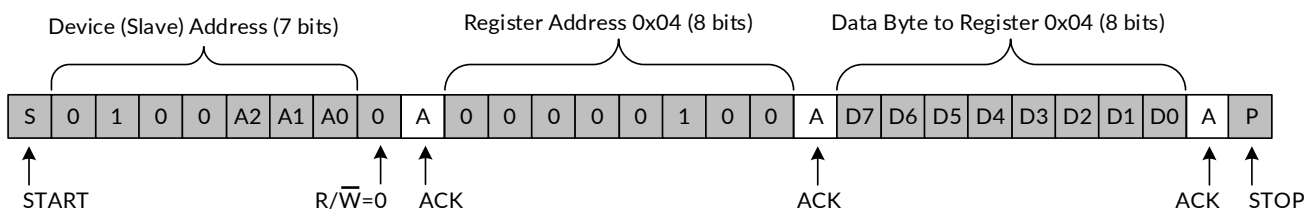
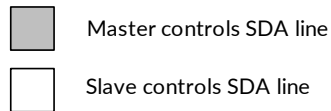
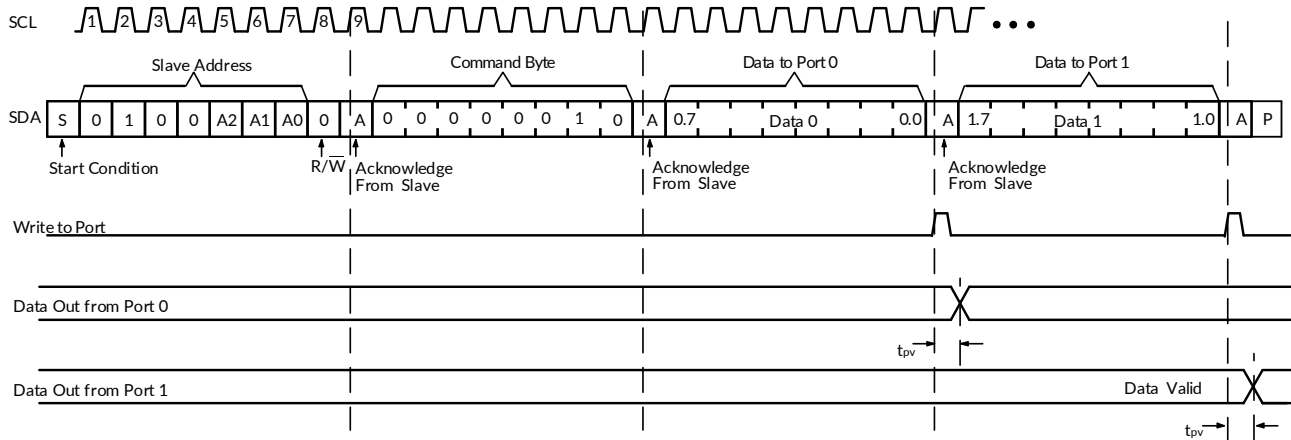

Figure 9. Write to the Polarity Inversion Register

Figure 10 shows the Write to Output Port Registers.

Figure 10. Write to Output Port Registers

9.5.1.1.2 Reads

Reading from a slave is very similar to writing, but requires some additional steps. In order to read from a slave, the master must first instruct the slave which register it wishes to read from. This is done by the master starting off the transmission in a similar fashion as the write, by sending the address with the R/\bar{W} bit equal to 0 (signifying a write), followed by the register address it wishes to read from. When the slave acknowledges this register address, the master sends a START condition again, followed by the slave address with the R/\bar{W} bit set to 1 (signifying a read). This time, the slave acknowledges the read request, and the master releases the SDA bus but continues supplying the clock to the slave. During this part of the transaction, the master becomes the master-receiver, and the slave becomes the slave-transmitter.

The master continues to send out the clock pulses, but releases the SDA line so that the slave can transmit data. At the end of every byte of data, the master sends an ACK to the slave, letting the slave know that it is ready for more data. When the master has received the number of bytes it is expecting, it sends a NACK, signaling to the slave to halt communications and release the bus. The master follows this up with a STOP condition.

See the Control Register and Command Byte section to see list of the RS29535's internal registers and a description of each one.

Figure 11 shows an example of reading a single byte from a slave register.

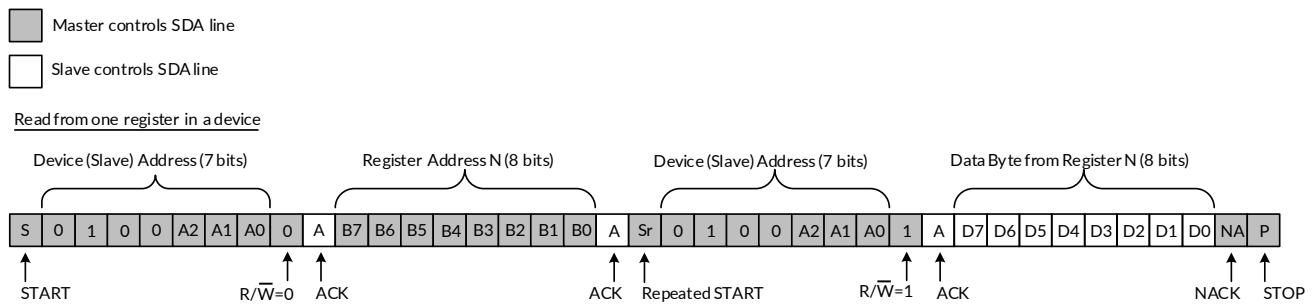
Figure 11. Read from Register

After a restart, the value of the register defined by the command byte matches the register being accessed when the restart occurred. For example, if the command byte references Input Port 1 before the restart, and the restart occurs when Input Port 0 is being read, the stored command byte changes to reference Input Port 0. The original command byte is forgotten. If a subsequent restart occurs, Input Port 0 is read first. Data is clocked into the register on the rising edge of the ACK clock pulse. After the first byte is read, additional bytes may be read, but the data now reflect the information in the other register in the pair. For example, if Input Port 1 is read, the next byte read is Input Port 0.

Data is clocked into the register on the rising edge of the ACK clock pulse. There is no limitation on the number of data bytes received in one read transmission, but when the final byte is received, the bus master must not acknowledge the data. Figure 12 and Figure 13 show two different scenarios of Read Input Port Register.

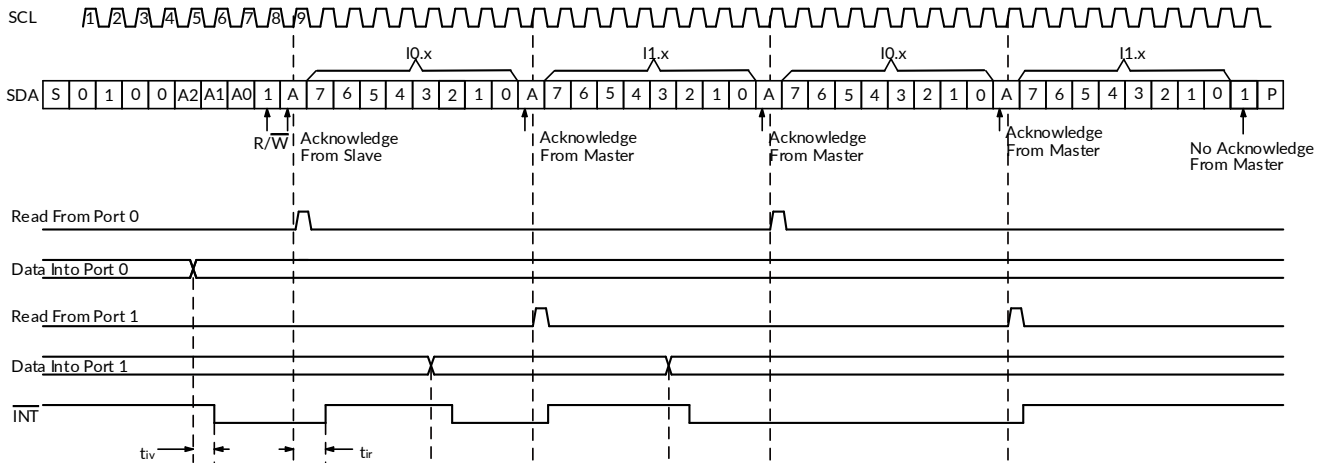

Transfer of data can be stopped at any time by a Stop condition. When this occurs, data present at the latest acknowledge phase is valid (output mode). It is assumed that the command byte previously has been set to 00 (read Input Port register). This figure eliminates the command byte transfer, a restart, and slave address call between the initial slave address call and actual data transfer from the P port.

Figure 12. Read Input Port Register, Scenario 1

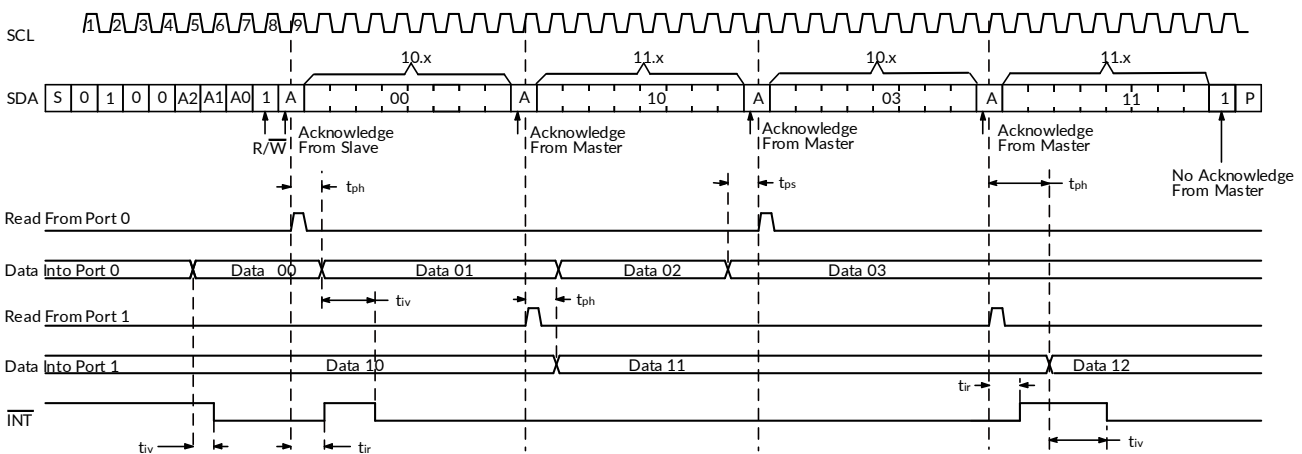

Transfer of data can be stopped at any time by a Stop condition. When this occurs, data present at the latest acknowledge phase is valid (output mode). It is assumed that the command byte previously has been set to 00 (read Input Port register). This figure eliminates the command byte transfer, a restart, and slave address call between the initial slave address call and actual data transfer from the P port.

Figure 13. Read Input Port Register, Scenario 2

9.5.2 Device Address

Figure 14 shows the address byte of the RS29535.

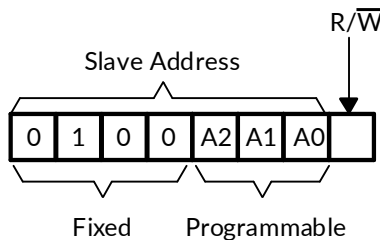

Figure 14. RS29535 Address

Table 2 shows the address reference of the RS29535.

Table 2. Address Reference

INPUTS			I ² C BUS SLAVE ADDRESS
A2	A1	A0	
L	L	L	32 (decimal), 0x20 (hexadecimal)
L	L	H	33 (decimal), 0x21 (hexadecimal)
L	H	L	34 (decimal), 0x22 (hexadecimal)
L	H	H	35 (decimal), 0x23 (hexadecimal)
H	L	L	36 (decimal), 0x24 (hexadecimal)
H	L	H	37 (decimal), 0x25 (hexadecimal)
H	H	L	38 (decimal), 0x26 (hexadecimal)
H	H	H	39 (decimal), 0x27 (hexadecimal)

The last bit of the slave address defines the operation (read or write) to be performed. A high (1) selects a read operation, while a low (0) selects a write operation.

9.5.3 Control Register and Command Byte

Following the successful acknowledgment of the address byte, the bus master sends a command byte shown in Table 3 that is stored in the control register in the RS29535. Three bits of this data byte state the operation (read or write) and the internal register (input, output, polarity inversion, or configuration) that is affected. This register can be written or read through the I²C bus. The command byte is sent only during a write transmission.

When a command byte has been sent, the register that was addressed continues to be accessed by reads until a new command byte has been sent. Figure 15 shows the control register bits.

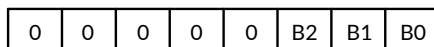
Figure 15. Control Register Bits
Table 3. Command Byte

CONTROL REGISTER BITS			COMMAND BYTE (HEX)	REGISTER	PROTOCOL	POWER-UP DEFAULT
B2	B1	B0				
0	0	0	0x00	Input Port 0	Read byte	xxxx xxxx
0	0	1	0x01	Input Port 1	Read byte	xxxx xxxx
0	1	0	0x02	Output Port 0	Read-write byte	1111 1111
0	1	1	0x03	Output Port 1	Read-write byte	1111 1111
1	0	0	0x04	Polarity Inversion Port 0	Read-write byte	0000 0000
1	0	1	0x05	Polarity Inversion Port 1	Read-write byte	0000 0000
1	1	0	0x06	Configuration Port 0	Read-write byte	1111 1111
1	1	1	0x07	Configuration Port 1	Read-write byte	1111 1111

9.6 Register Maps

9.6.1 Register Descriptions

The Input Port registers (registers 0 and 1) shown in Table 4 reflect the incoming logic levels of the pins, regardless of whether the pin is defined as an input or an output by the Configuration Register. It only acts on read operation. Writes to these registers have no effect. The default value, X, is determined by the externally applied logic level.

Before a read operation, a write transmission is sent with the command byte to let the I²C device know that the Input Port registers are accessed next.

Table 4. Registers 0 and 1 (Input Port Registers)

Bit	I0.7	I0.6	I0.5	I0.4	I0.3	I0.2	I0.1	I0.0
Default	X	X	X	X	X	X	X	X
Bit	I1.7	I1.6	I1.5	I1.4	I1.3	I1.2	I1.1	I1.0
Default	X	X	X	X	X	X	X	X

The Output Port registers (registers 2 and 3) shown in Table 5 show the outgoing logic levels of the pins defined as outputs by the Configuration register. Bit values in this register have no effect on pins defined as inputs. In turn, reads from this register reflect the value that is in the flip-flop controlling the output selection, not the actual pin value.

Table 5. Registers 2 and 3 (Output Port Registers)

Bit	O0.7	O0.6	O0.5	O0.4	O0.3	O0.2	O0.1	O0.0
Default	1	1	1	1	1	1	1	1
Bit	O1.7	O1.6	O1.5	O1.4	O1.3	O1.2	O1.1	O1.0
Default	1	1	1	1	1	1	1	1

The Polarity Inversion registers (registers 4 and 5) shown in Table 6 allow polarity inversion of pins defined as inputs by the Configuration register. If a bit in this register is set (written with 1), the corresponding pin's polarity is inverted. If a bit in this register is cleared (written with a 0), the corresponding pin's original polarity is retained.

Table 6. Registers 4 and 5 (Polarity Inversion Registers)

Bit	N0.7	N0.6	N0.5	N0.4	N0.3	N0.2	N0.1	N0.0
Default	0	0	0	0	0	0	0	0
Bit	N1.7	N1.6	N1.5	N1.4	N1.3	N1.2	N1.1	N1.0
Default	0	0	0	0	0	0	0	0

The Configuration registers (registers 6 and 7) shown in Table 7 configure the directions of the I/O pins. If a bit in this register is set to 1, the corresponding port pin is enabled as an input with a high-impedance output driver. If a bit in this register is cleared to 0, the corresponding port pin is enabled as an output.

Table 7. Registers 6 and 7 (Configuration Registers)

Bit	C0.7	C0.6	C0.5	C0.4	C0.3	C0.2	C0.1	C0.0
Default	1	1	1	1	1	1	1	1
Bit	C1.7	C1.6	C1.5	C1.4	C1.3	C1.2	C1.1	C1.0
Default	1	1	1	1	1	1	1	1

10 APPLICATION AND IMPLEMENTATION

Information in the following applications sections is not part of the Runic component specification, and Runic does not warrant its accuracy or completeness. Runic's customers are responsible for determining suitability of components for their purposes. Customers should validate and test their design implementation to confirm system functionality.

10.1 Application Information

Applications of the RS29535 has this device connected as a slave to an I²C master (processor), and the I²C bus may contain any number of other slave devices. The RS29535 is typically in a remote location from the master, placed close to the GPIOs to which the master needs to monitor or control.

IO Expanders such as the RS29535 are typically used for controlling LEDs (for feedback or status lights), controlling enable or reset signals of other devices, and even reading the outputs of other devices or buttons.

10.2 Typical Application

Figure 16 shows an application in which the RS29535 can be used.

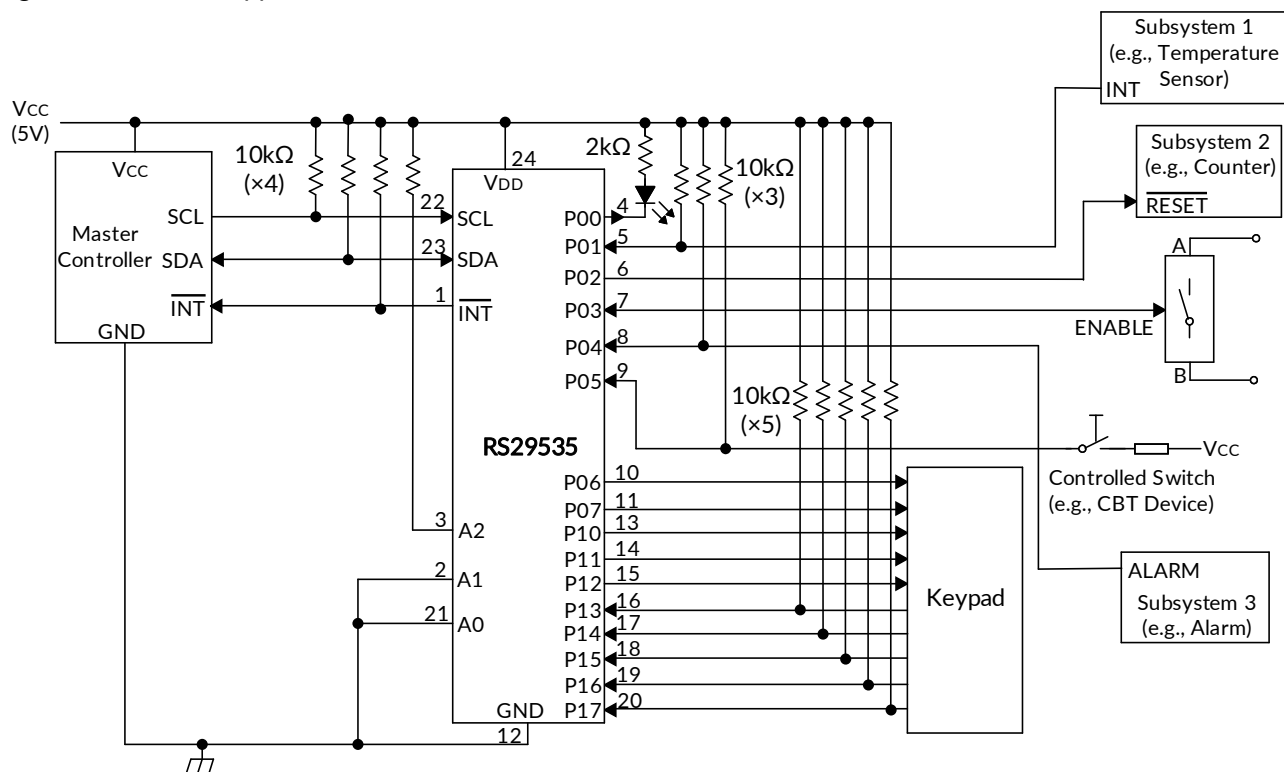

Device address is configured as 0100100 for this example.

P00, P02, and P03 are configured as outputs.

P01, P04-P07, and P10-P17 are configured as inputs.

Pin numbers shown are for the TSSOP24 package.

Figure 16. Application Schematic

10.2.1 Design Requirements

The designer must take into consideration the system, to be sure not to violate any of the parameters. Table 8 shows some key parameters which must not be violated.

Table 8. Design Parameters

DESIGN PARAMETER	EXAMPLE VALUE
I ² C and Subsystem Voltage (V _{CC})	5V
Output current rating, P-port sinking (I _{OL})	25mA
I ² C bus clock (SCL) speed	400kHz

10.2.1.1 Calculating Junction Temperature and Dissipation

When designing with this device, it is important that the Recommended Operating Conditions not be violated. Many of the parameters of this device are rated based on junction temperature. So junction temperature must be calculated in order to verify that safe operation of the device is met. The basic equation for junction temperature is shown in Equation 1.

$$T_j = T_A + (\theta_{JA} \times P_d) \quad (1)$$

θ_{JA} is the standard junction to ambient thermal resistance measurement of the package, as seen in Thermal Information table. P_d is the total power dissipation of the device, and the approximation is shown in Equation 2.

$$P_d \approx (I_{CC_STATIC} \times V_{CC}) + \sum P_{d_PORT_L} + \sum P_{d_PORT_H} \quad (2)$$

Equation 2 is the approximation of power dissipation in the device. The equation is the static power plus the summation of power dissipated by each port (with a different equation based on if the port is outputting high, or outputting low. If the port is set as an input, then power dissipation is the input leakage of the pin multiplied by the voltage on the pin). Note that this ignores power dissipation in the INT and SDA pins, assuming these transients to be small. They can easily be included in the power dissipation calculation by using Equation 3 to calculate the power dissipation in INT or SDA while they are pulling low, and this gives maximum power dissipation.

$$P_{d_PORT_L} = (I_{OL} \times V_{OL}) \quad (3)$$

Equation 3 shows the power dissipation for a single port which is set to output low. The power dissipated by the port is the V_{OL} of the port multiplied by the current it is sinking.

$$P_{d_PORT_H} = (I_{OH} \times (V_{CC} - V_{OH})) \quad (4)$$

Equation 4 shows the power dissipation for a single port which is set to output high. The power dissipated by the port is the current sourced by the port multiplied by the voltage drop across the device (difference between V_{CC} and the output voltage).

10.2.1.2 Minimizing I_{CC} When I/O is Used to Control LED

When an I/O is used to control an LED, normally it is connected to V_{CC} through a resistor as shown in Figure 16. Because the LED acts as a diode, when the LED is off, the I/O V_{IN} is about 1.2 V less than V_{CC} . The ΔI_{CC} parameter in the Electrical Characteristics table shows how I_{CC} increases as V_{IN} becomes lower than V_{CC} . For battery-powered applications, it is essential that the voltage of I/O pins is greater than or equal to V_{CC} when the LED is off to minimize current consumption.

Figure 17 shows a high-value resistor in parallel with the LED. Figure 18 shows V_{CC} less than the LED supply voltage by at least 1.2V. Both of these methods maintain the I/O V_{IN} at or above V_{CC} and prevent additional supply current consumption when the LED is off.

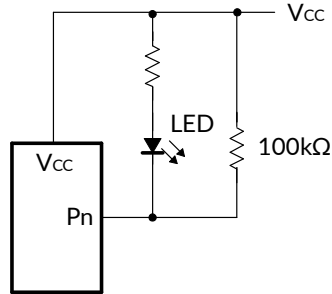
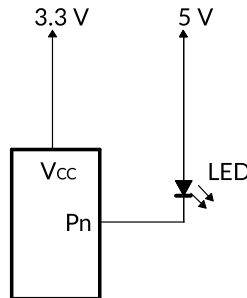
Figure 17. High-Value Resistor in Parallel With LED

Figure 18. Device Supplied by Lower Voltage

10.2.2 Detailed Design Procedure

The pull-up resistors, R_P , for the SCL and SDA lines need to be selected appropriately and take into consideration the total capacitance of all slaves on the I²C bus. The minimum pull-up resistance is a function of V_{CC} , $V_{OL(max)}$, and I_{OL} as shown in Equation 5.

$$R_{P(min)} = \frac{V_{CC} - V_{OL(max)}}{I_{OL}} \quad (5)$$

The maximum pull-up resistance is a function of the maximum rise time, t_r (300 ns for fast-mode operation, $f_{SCL} = 400$ kHz) and bus capacitance, C_b as shown in Equation 6.

$$R_{P(max)} = \frac{t_r}{0.8473 \times C_b} \quad (6)$$

The maximum bus capacitance for an I²C bus must not exceed 400pF for standard-mode or fast-mode operation. The bus capacitance can be approximated by adding the capacitance of the RS29535, C_i for SCL or C_{IO} for SDA, the capacitance of wires/connections/traces, and the capacitance of additional slaves on the bus.

11 PACKAGE OUTLINE DIMENSIONS

TSSOP24 (3)

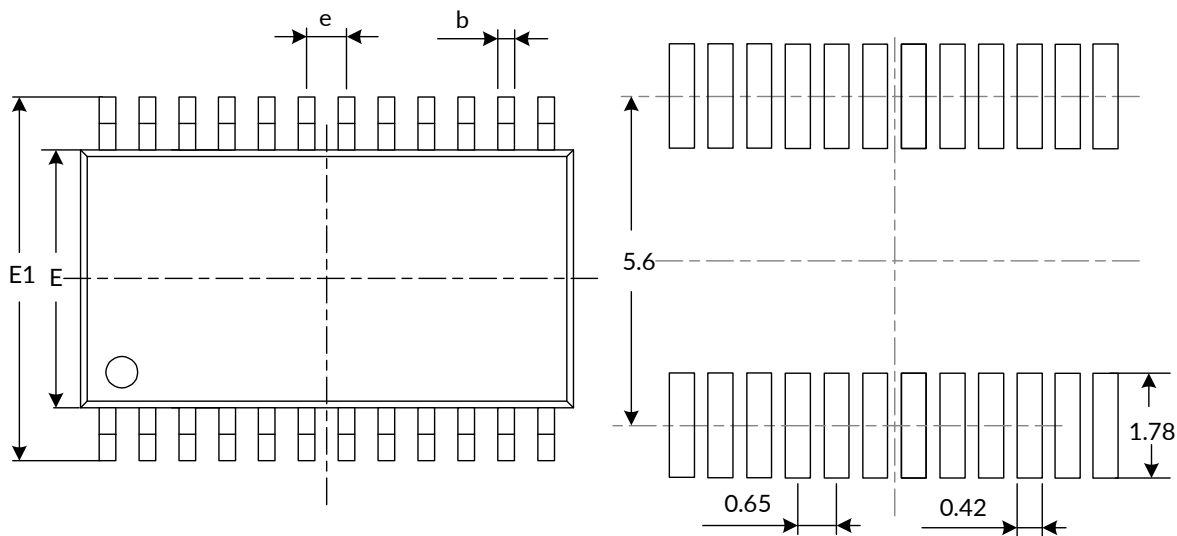

RECOMMENDED LAND PATTERN (Unit: mm)

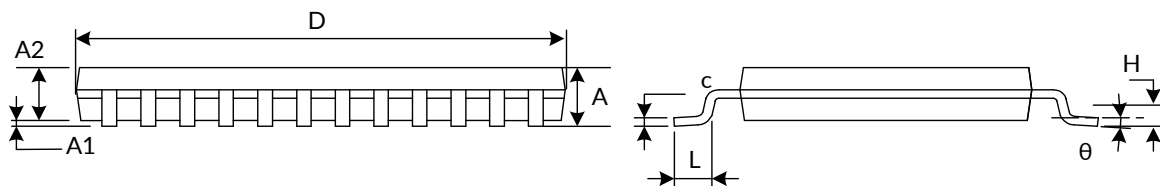

Symbol	Dimensions In Millimeters		Dimensions In Inches	
	Min	Max	Min	Max
A ⁽¹⁾		1.200		0.047
A1	0.050	0.150	0.002	0.006
A2	0.800	1.050	0.031	0.041
b	0.200	0.290	0.008	0.011
c	0.130	0.170	0.005	0.007
D ⁽¹⁾	7.700	7.900	0.303	0.311
E ⁽¹⁾	4.300	4.500	0.169	0.177
E1	6.200	6.600	0.244	0.260
e	0.650 (BSC) ⁽²⁾		0.026 (BSC) ⁽²⁾	
L	0.450	0.750	0.018	0.030
H	0.250 (TYP)		0.010 (TYP)	
theta	0°	8°	0°	8°

NOTE:

1. Plastic or metal protrusions of 0.15mm maximum per side are not included.
2. BSC (Basic Spacing between Centers), "Basic" spacing is nominal.
3. This drawing is subject to change without notice.

12 TAPE AND REEL INFORMATION

REEL DIMENSIONS

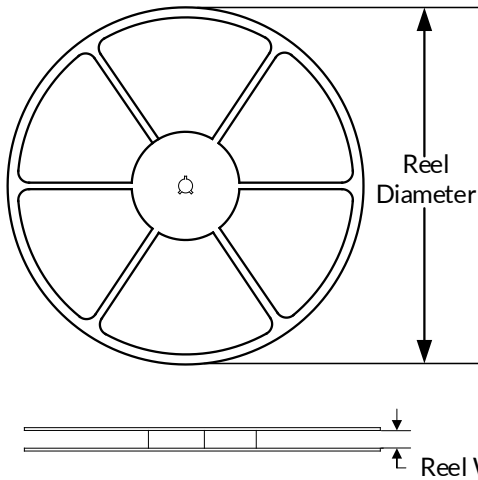

TAPE DIMENSION

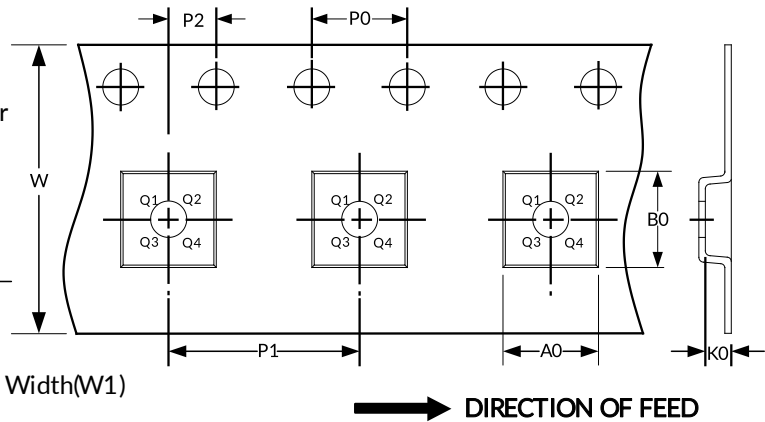

NOTE: The picture is only for reference. Please make the object as the standard.

KEY PARAMETER LIST OF TAPE AND REEL

Package Type	Reel Diameter	Reel Width (mm)	A0 (mm)	B0 (mm)	K0 (mm)	P0 (mm)	P1 (mm)	P2 (mm)	W (mm)	Pin1 Quadrant
TSSOP24	13"	16.4	6.95	8.30	1.60	4.0	8.0	2.0	16.0	Q1

NOTE:

1. All dimensions are nominal.
2. Plastic or metal protrusions of 0.15mm maximum per side are not included.

IMPORTANT NOTICE AND DISCLAIMER

Jiangsu Runic Technology Co., Ltd. will accurately and reliably provide technical and reliability data (including data sheets), design resources (including reference designs), application or other design advice, WEB tools, safety information and other resources, without warranty of any defect, and will not make any express or implied warranty, including but not limited to the warranty of merchantability Implied warranty that it is suitable for a specific purpose or does not infringe the intellectual property rights of any third party.

These resources are intended for skilled developers designing with Runic products You will be solely responsible for: (1) Selecting the appropriate products for your application; (2) Designing, validating and testing your application; (3) Ensuring your application meets applicable standards and any other safety, security or other requirements; (4) Runic and the Runic logo are registered trademarks of Runic Incorporated. All trademarks are the property of their respective owners; (5) For change details, review the revision history included in any revised document. The resources are subject to change without notice. Our company will not be liable for the use of this product and the infringement of patents or third-party intellectual property rights due to its use.